

A Seamless Framework for the Global Monitoring and Prediction of Droughts

Eric F Wood
Land Surface Hydrology Group
Princeton University



APEC Climate Conference 2014

Managing Climate Extreme and Hydrologic Disasters: Scientific
Prediction and Emergency Preparedness

October 27-29, 2014

Nanjing, China



Droughts arguably cause the most impacts of all natural hazards in terms of the number of people affected and the long-term economic costs and ecosystem stresses.

Reduced water levels/supply: public, industry and power generation



NY Times



Reduced agricultural, forestry and fisheries productivity



BBC

Increased livestock and wildlife mortality rates



John Mccolgan/US Forest Service

Increased fire hazard/tree die off

Damage to wildlife habitat



BBC

Droughts arguably cause the most impacts of all natural hazards in terms of the number of people affected and the long-term economic costs and ecosystem stresses.

Reduced water levels/supply: public, industry and power generation

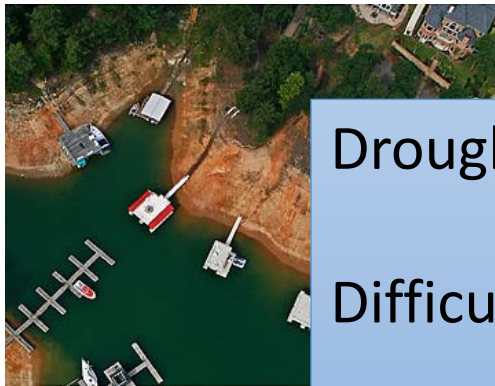

NY Times

Reduced agricultural, forestry and fisheries productivity



BBC

Drought is a slowly evolving natural hazard

Difficult to quantify and track in time

Impacts may be subtle and far-reaching

and wildlife

mortality rates



John Mccolgan/US Forest Service

Increased fire hazard/tree die off

Damage to wildlife habitat



BBC

The Cost of Drought

\$billion disasters U.S. 1980-2003

Disaster type	Number of events	Frequency (%)	Damages (\$US Billion)	Damages (%)
Tropical Storms/Hurricanes	16	28.0	102	29.2
Non-tropical floods	12	21	55	15.8
Heatwaves and droughts	10	17	144	41.2
Severe weather	7	12	13	3.7
Fires	6	10	13	3.7
Freezing weather	2	3.5	6	1.7
Blizzards	2	3.5	9	2.6
Ice storms	2	3.5	5	1.4
Noreaster	1	1.5	2	0.7
Total	58		349	

Source: NCDC

The Human Cost of Drought

Country	Date	Deaths
China P Rep, Drought	1928	3,000,000
Bangladesh, Drought	1943	1,900,000
India, Drought	1942	1,500,000
India, Drought	1965	1,500,000
India, Drought	1900	1,250,000
Soviet Union, Drought	1921	1,200,000
China P Rep, Drought	1920	500,000
Ethiopia, Drought	May-83	300,000
Sudan, Drought	Apr-83	150,000
Ethiopia, Drought	Dec-73	100,000

Most recent famine in Horn of Africa (2011):
50,000-100,000 deaths

Source: "EM-DAT: The OFDA/CRED International
Disaster Database.
www.em-dat.net - Université Catholique de
Louvain - Brussels - Belgium

2010

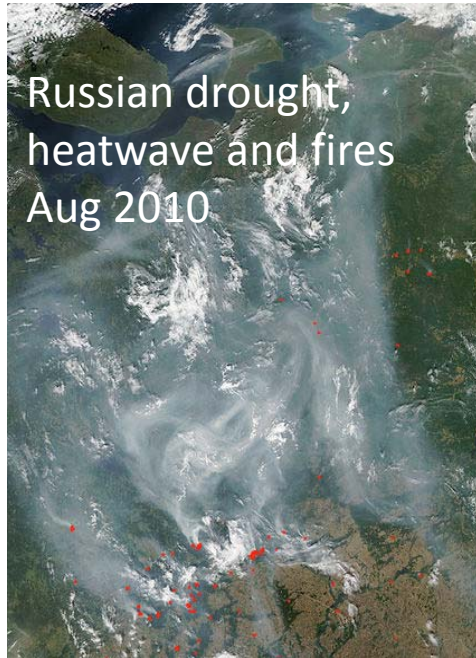

2011

TEXAS DROUGHT HEADLINES:

- "Texas Drought Endangers Power Projects"*
- "Texas Drought Will Mar Landscape For Years"*
- "Amid Drought, Texas Slow To Prepare For Future Water Needs"*
- "Multi-Billion Dollar Drought to Drive Beef Prices Up"*
- "Major Fish Evacuations Planned For Texas River Facing Drought"*
- "Texas Drought: 'Tough Choices' Ahead For The Thirsty State"*



Drought and Famine in East Africa

Areas affected

Total numbers in need of humanitarian assistance across the region:

12.4 million

Dadaab refugee camp

Over 1,000 arrivals each day, 25% of new arrivals' children are malnourished

Dollo Ado refugee camp

54,000 new arrivals in 2011, 50% of new arrivals' children are malnourished

Key:

■ Estimated population in need of assistance:

Food security situation:

- None or minimal
- Stressed
- Crisis
- Emergency
- Catastrophe/famine
- Limited humanitarian access

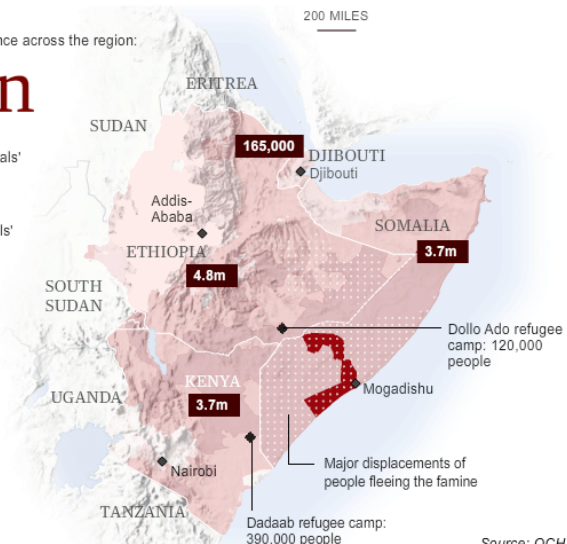

O.C. Fisher Lake, TX, Aug 2011 (Tony Gutierrez, AP)



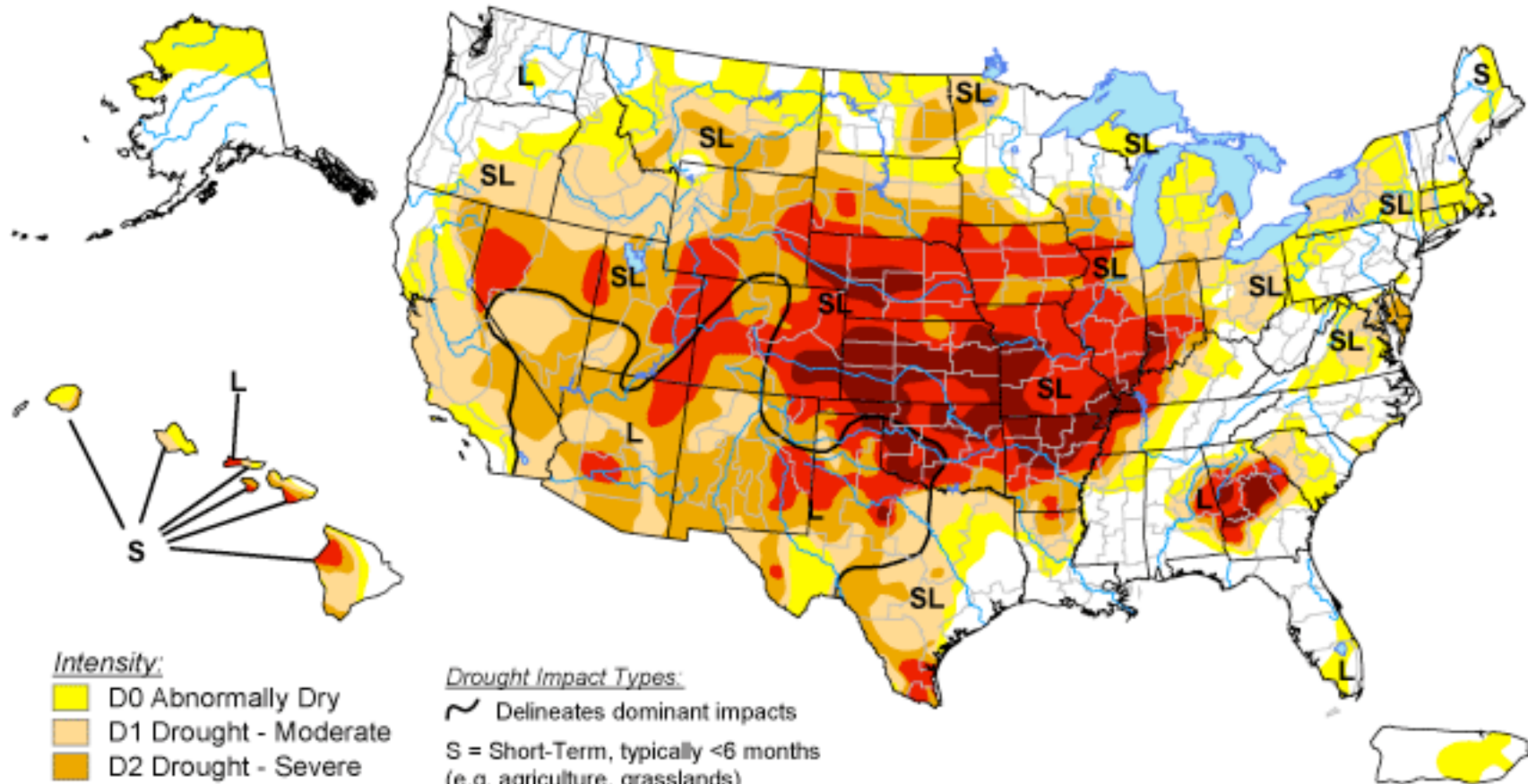

Plus many others:

- Drought in Shandong Province, China
- Drought and wildfire in western Australia
- Extreme spring drought in W. Europe
- Drought in Cuba in early summer
- Severe drought in Argentina and S. Brazil
- Late year drought in eastern Europe

2012



Intensity:

-  D0 Abnormally Dry
-  D1 Drought - Moderate
-  D2 Drought - Severe
-  D3 Drought - Extreme
-  D4 Drought - Exceptional

Drought Impact Types:

-  Delineates dominant impacts
- S = Short-Term, typically <6 months (e.g. agriculture, grasslands)
- L = Long-Term, typically >6 months (e.g. hydrology, ecology)

The Drought Monitor focuses on broad-scale conditions. Local conditions may vary. See accompanying text summary for forecast statements.



Released Thursday, August 23, 2012

<http://droughtmonitor.unl.edu/>

Author: Michael Brewer/Liz Love-Brotak, NOAA/NESDIS/NCDC

2013/14

U.S. Drought Monitor California

March 11, 2014
(Released Thursday, Mar. 13, 2014)
Valid 7 a.m. EDT

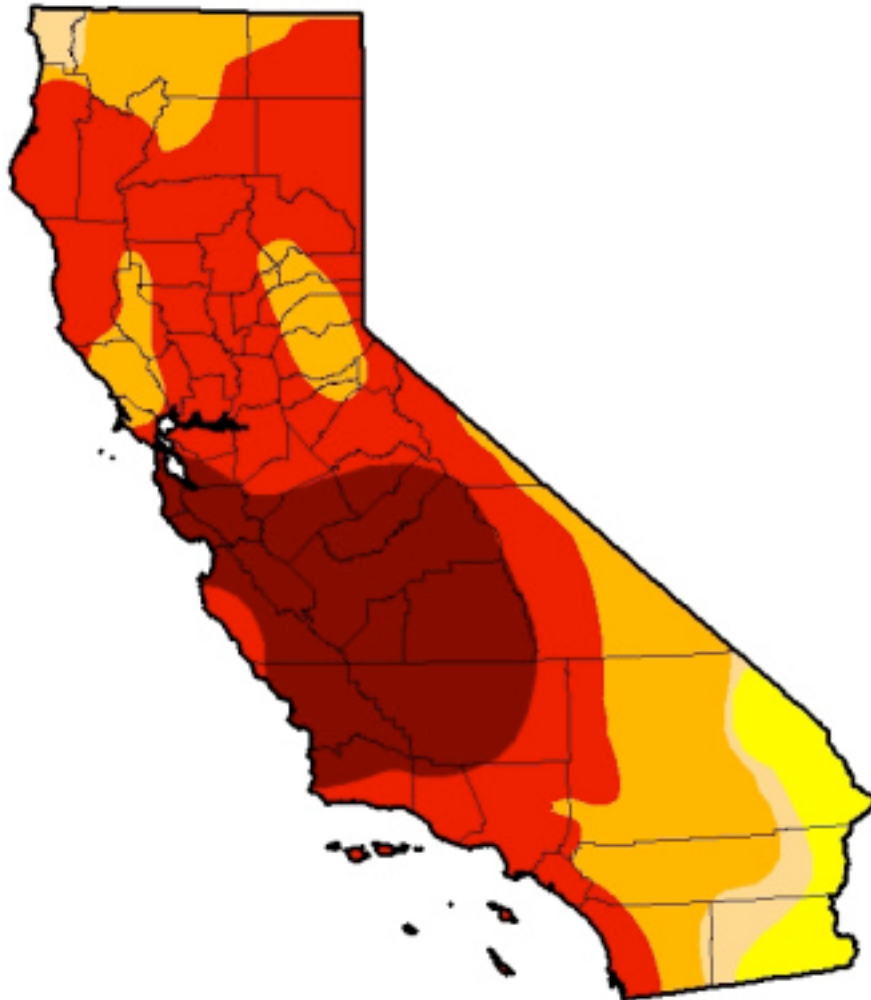

Drought Conditions (Percent Area)

	None	D0-D4	D1-D4	D2-D4	D3-D4	D4
Current	0.01	99.99	94.56	90.81	65.89	22.37
Last Week 3/4/2014	0.00	100.00	94.56	90.82	65.89	22.37
3 Months Ago 12/10/2013	2.61	97.39	94.15	82.53	27.59	0.00
Start of Calendar Year 12/01/2013	2.61	97.39	94.25	87.53	27.59	0.00
Start of Water Year 10/1/2013	2.63	97.37	95.95	84.12	11.36	0.00
One Year Ago 3/12/2013	15.63	84.37	46.23	24.19	0.00	0.00

Intensity:

- D0 Abnormally Dry
- D1 Moderate Drought
- D2 Severe Drought
- D3 Extreme Drought
- D4 Exceptional Drought

The Drought Monitor focuses on broad-scale conditions. Local conditions may vary. See accompanying text summary for forecast statements.

Author:
Richard Tinker
CPC/NOAA/NWS/NCEP



<http://droughtmonitor.unl.edu/>

Timelines of analysis for a seamless Global Water Cycle Information System

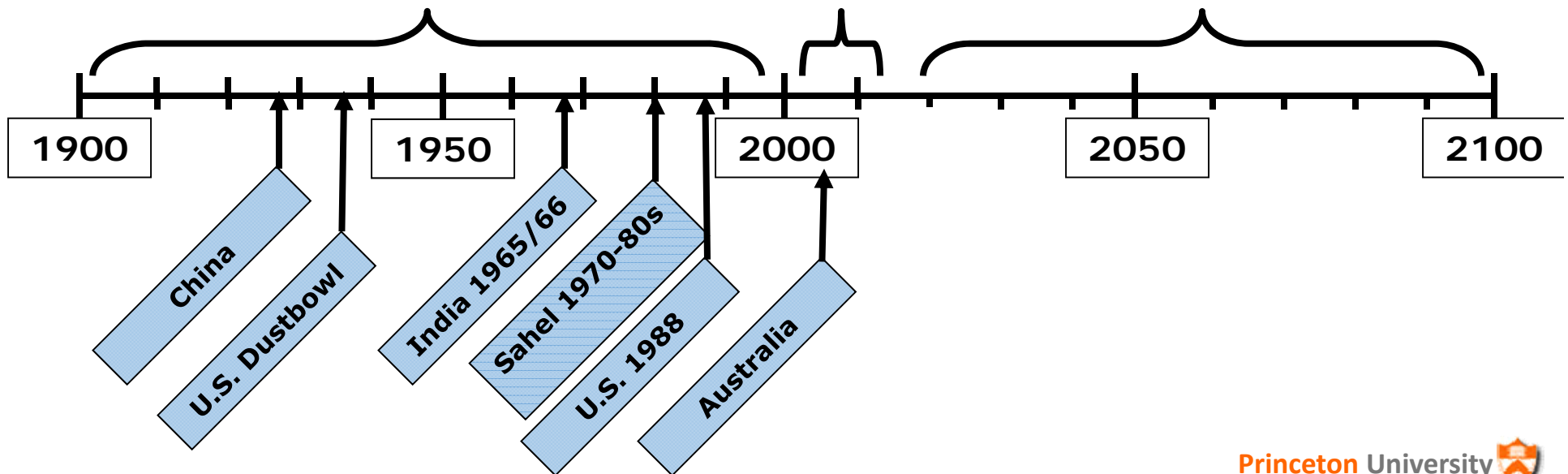
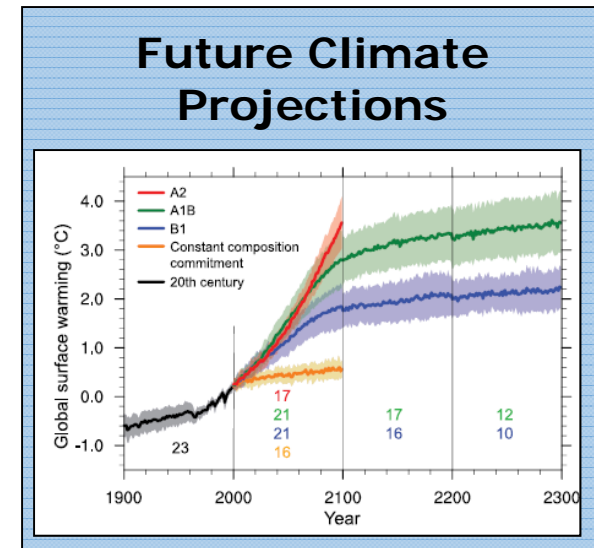
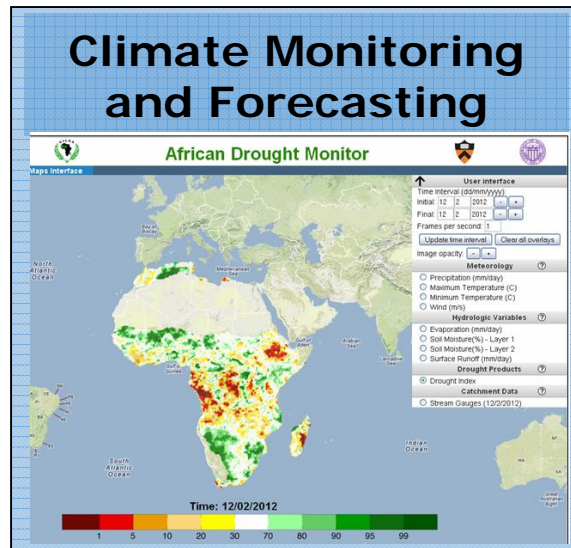
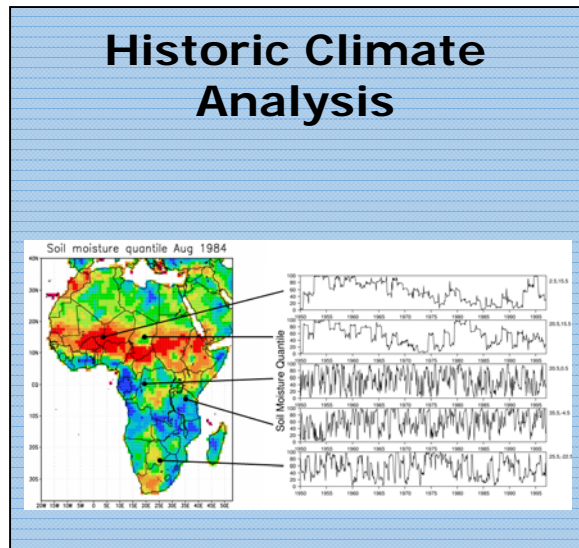

How do we reduce the impacts of drought?

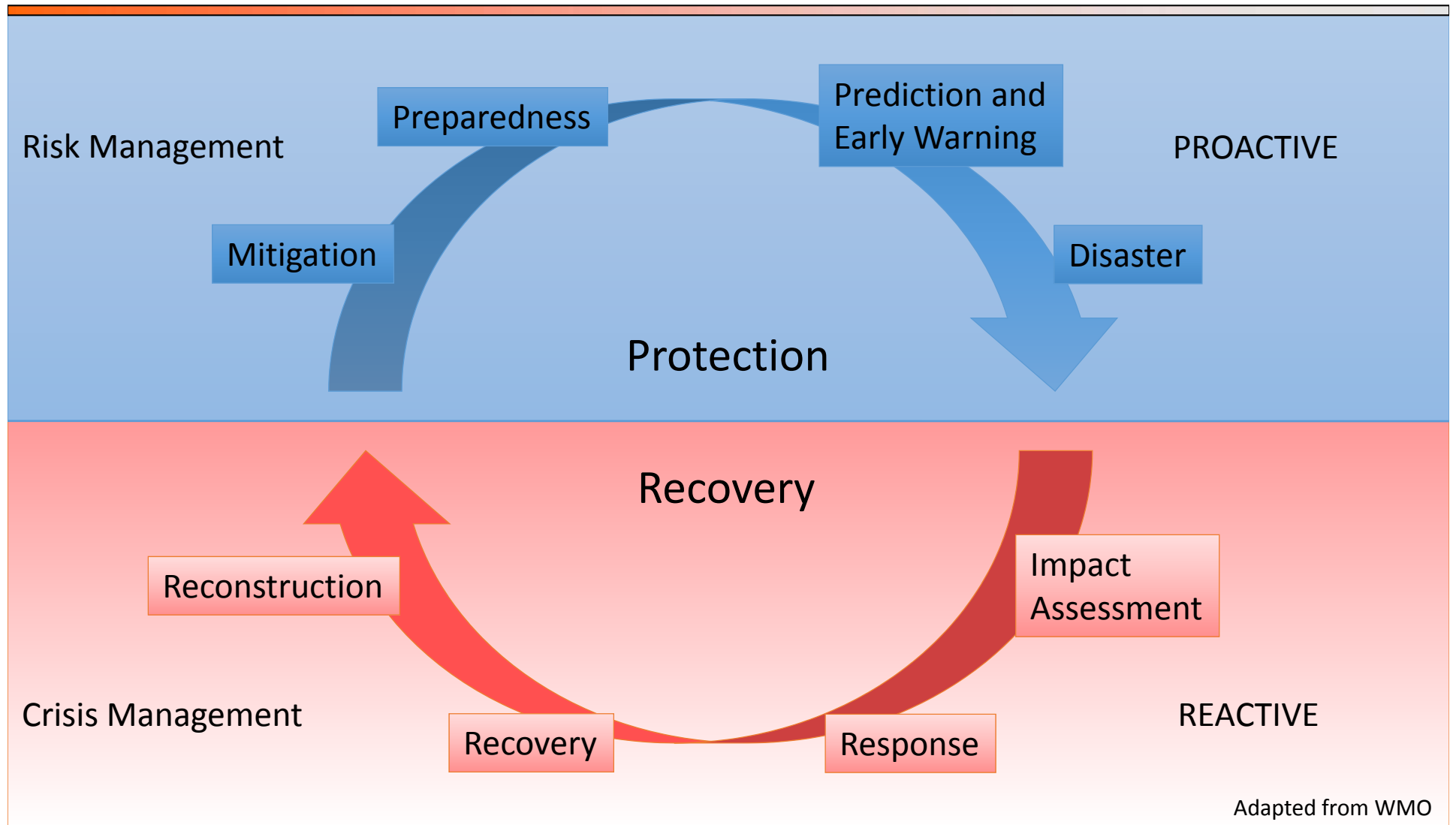

US Federal Emergency Management Agency (FEMA) and other disaster management organizations estimate that for every \$1 spent on reducing vulnerability to disaster \$4 is saved.

How do we reduce the impacts of drought?

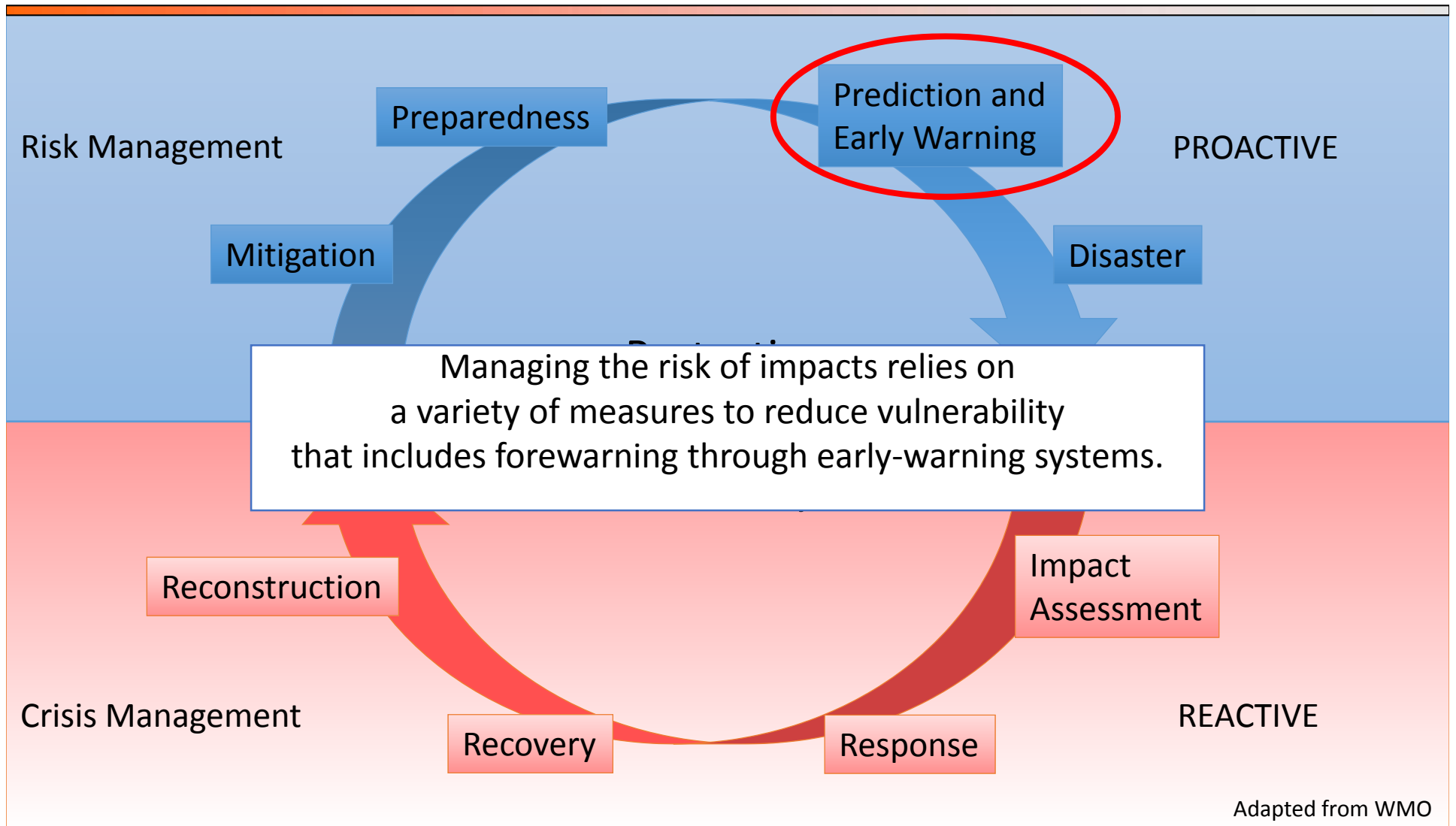

US Federal Emergency Management Agency (FEMA) and other disaster management organizations estimate that for every \$1 spent on reducing vulnerability to disaster \$4 is saved.

What are the scientific challenges?

2. Historic Drought Occurrence and Long-Term Change

3. Mechanisms of drought initiation, persistence and recovery

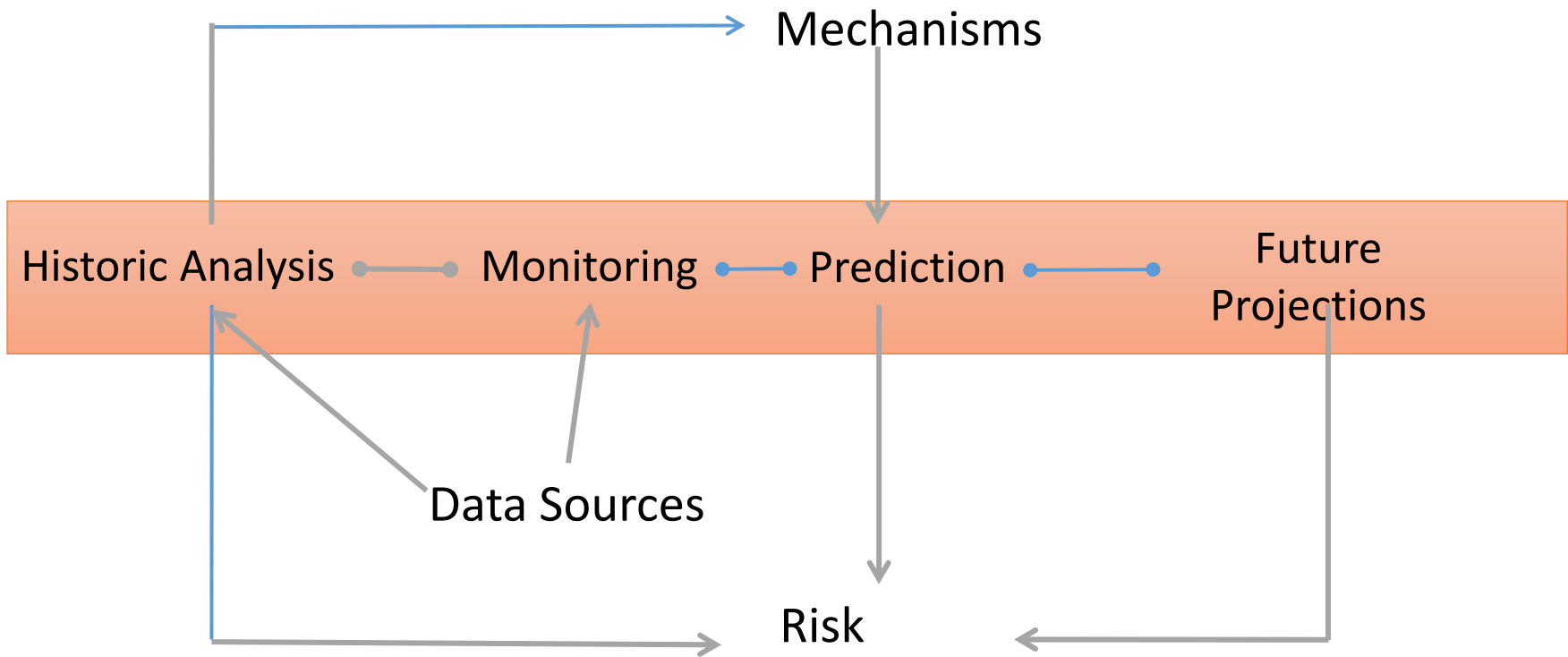

1. Data sources for improved monitoring

4. Uncertainty in future climate projections

What are the scientific challenges?

2. Historic Drought Occurrence and Long-Term Change

3. Mechanisms of drought initiation, persistence and recovery

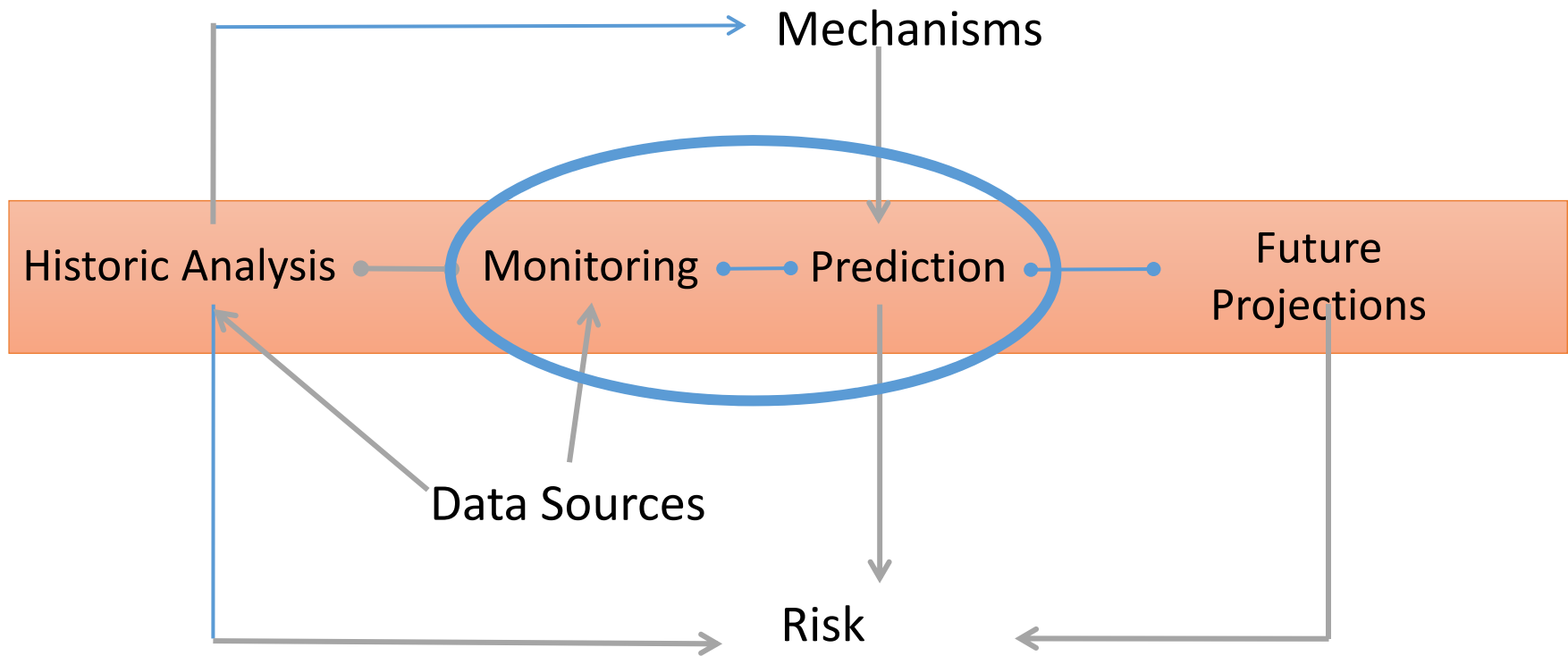

1. Data sources for improved monitoring

4. Uncertainty in future climate projections

The elements of a Seamless Monitoring and Prediction Framework Across Time Scales

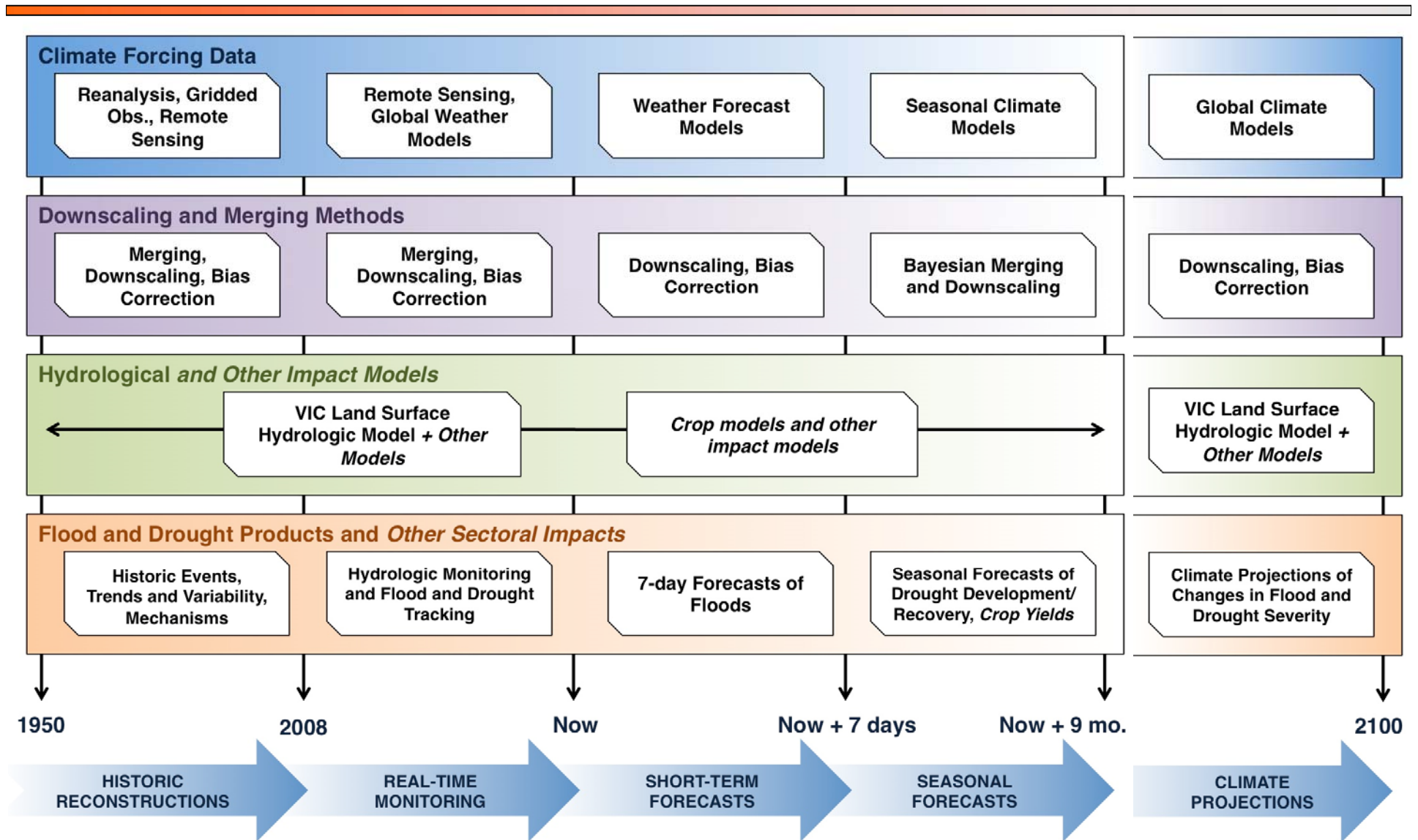

Sheffield, J., et al., 2014; A drought monitoring and forecasting system for sub-Saharan African water resources and food security. *Bull. Am. Met. Soc.*

1. Data Sources: Terrestrial Hydrological Budget based on Modeling

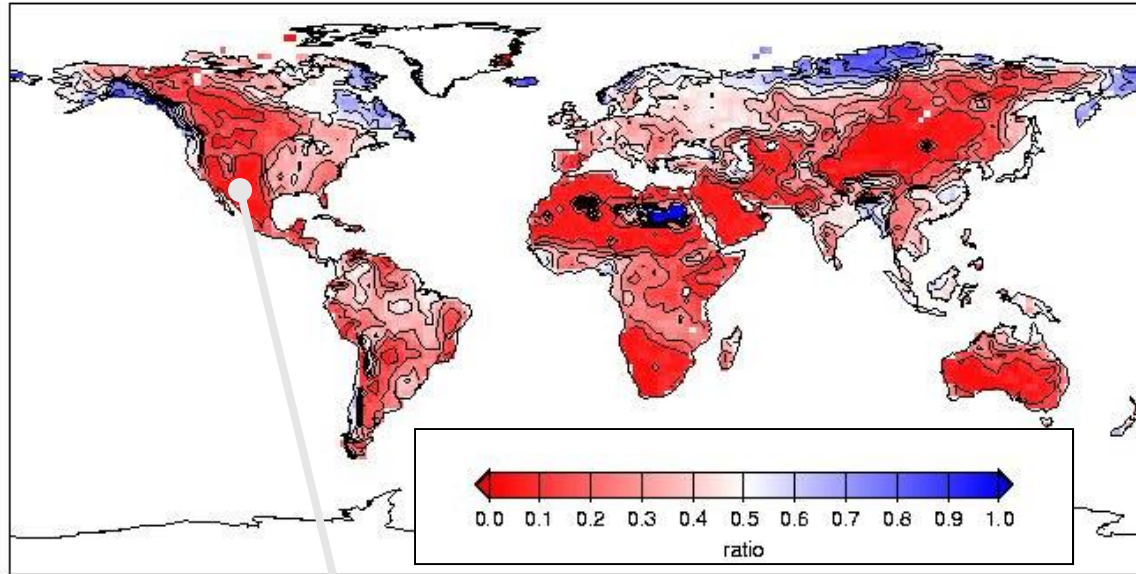

Input Parameters

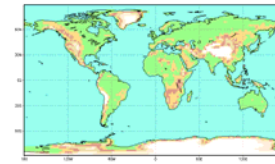

Elevation

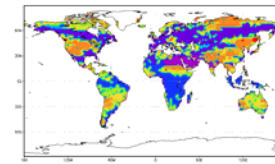

Dominant Vegetation

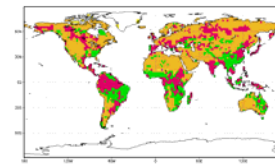

Soil properties

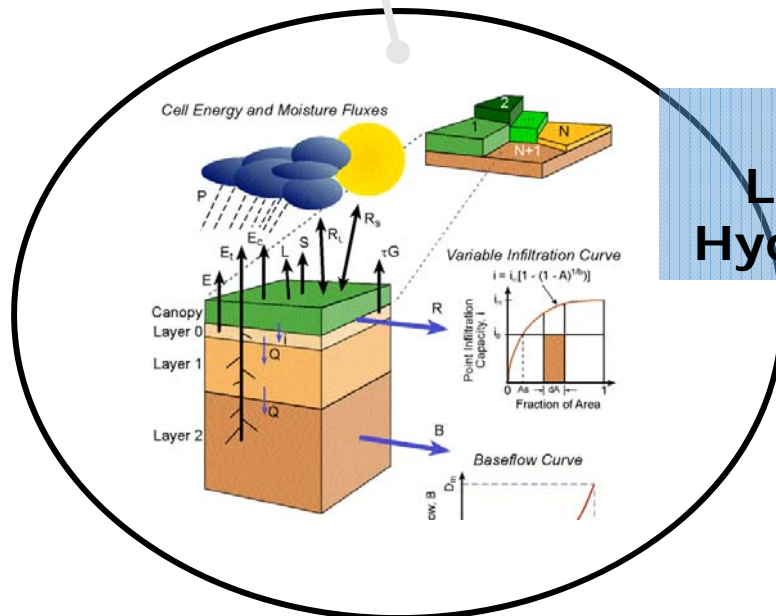

VIC Land Surface Hydrology Model

- Global land except Antarctica and Greenland
- 0.25 degree grid resolution
- 1950-2010, now being extended to NRT

1. Global Model Validation

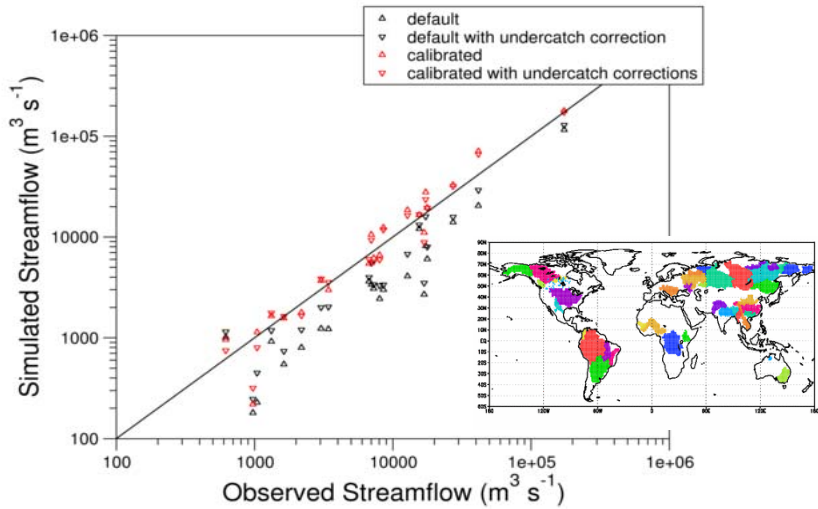

Soil Moisture
Point soil moisture
comparisons over US,
China, India, former
Soviet Union...

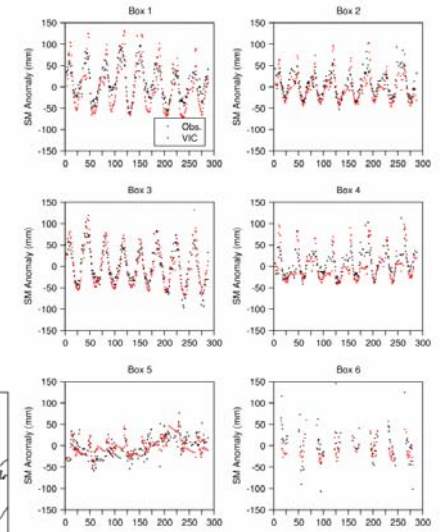

Streamflow Comparison with large basin streamflow observations

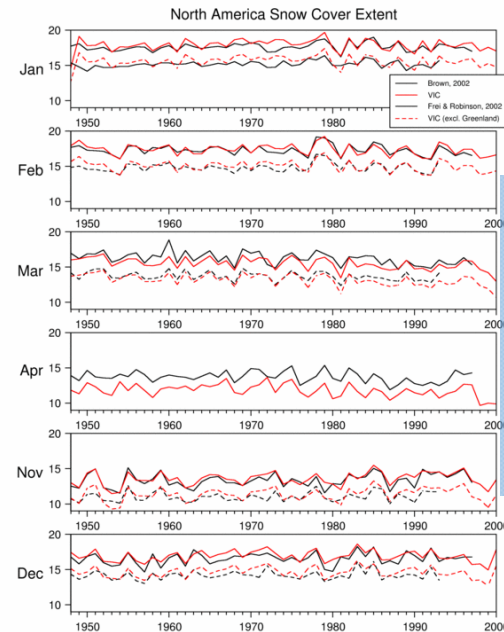
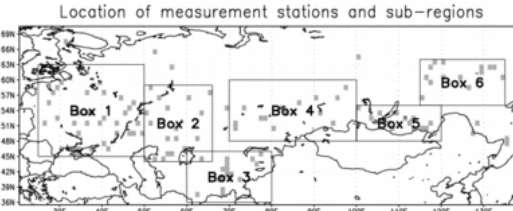
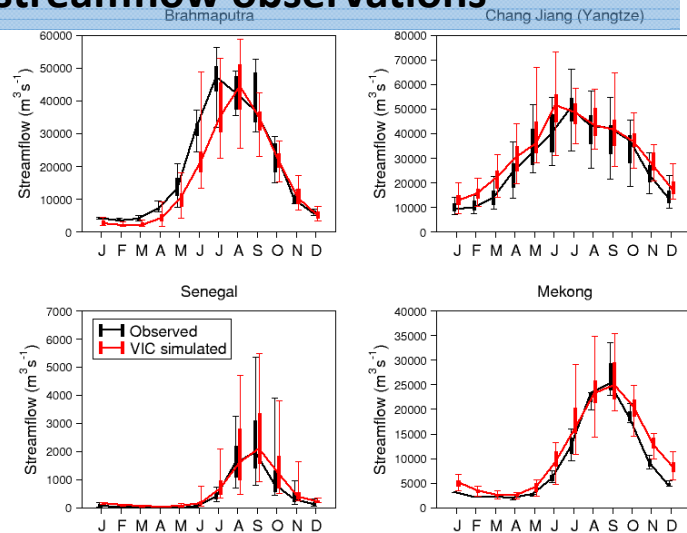

Snow Cover
Continental scale
comparison with
remote sensing based
snow cover extent

1. Derived variables: Development of a Soil Moisture Drought Index

1) Retrospective Simulation

Forcings



VIC Model
(MME LSM)



Retrospective Soil Moisture

2) Calculate Drought Index: drought = run of low soil moisture

Fit beta distribution



Soil Moisture Percentile



Drought Index

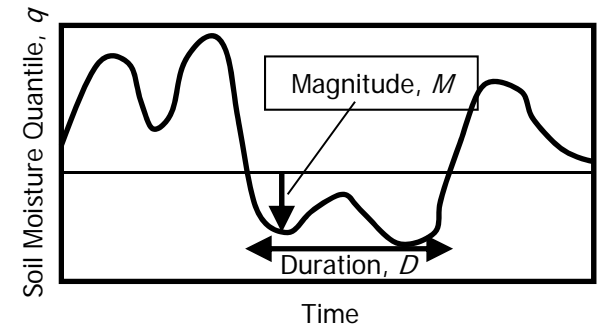
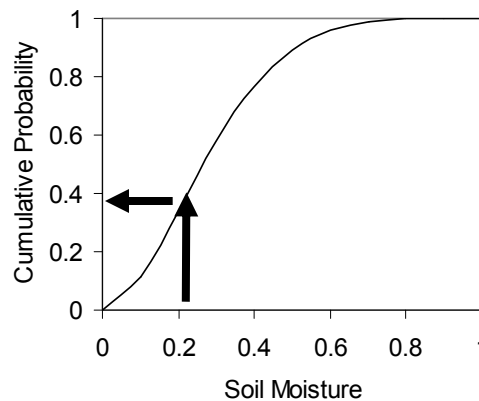
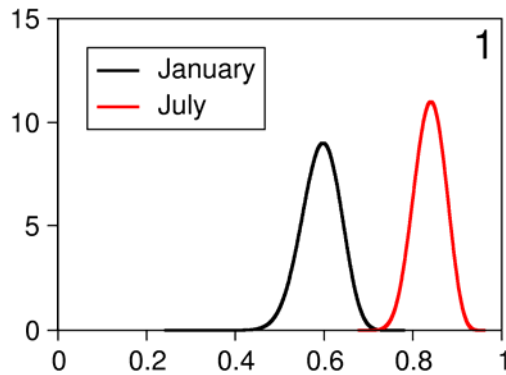

$$\text{Severity, } S = D \times M$$

$$\text{Extent, } A = \text{area in drought}$$

3) Drought Analysis

Trends/Var

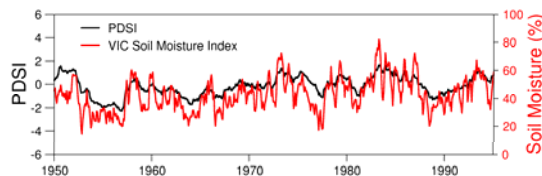

Characteristics

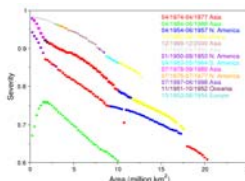

Monitoring

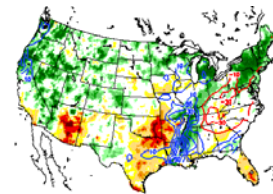

Climate Change

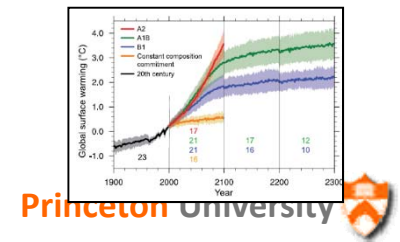

2. Historical Analysis: Drought Quantiles for Specific Events

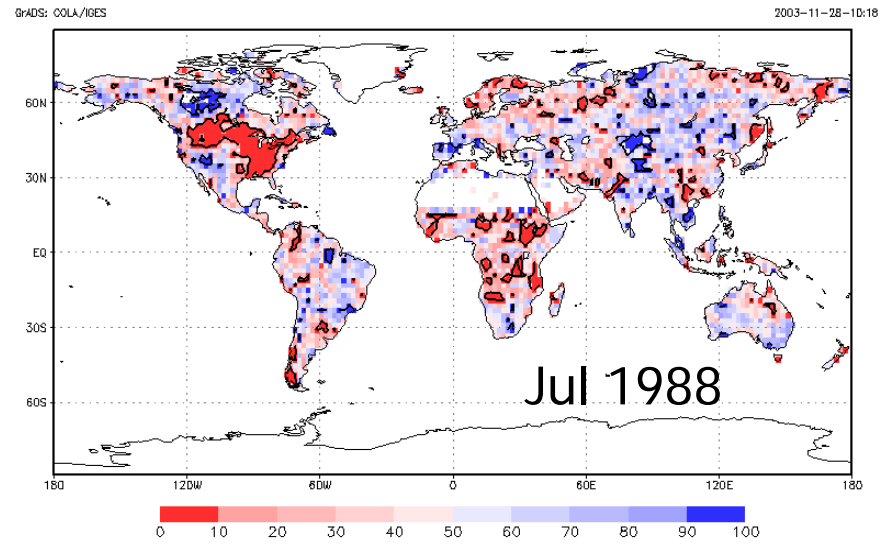
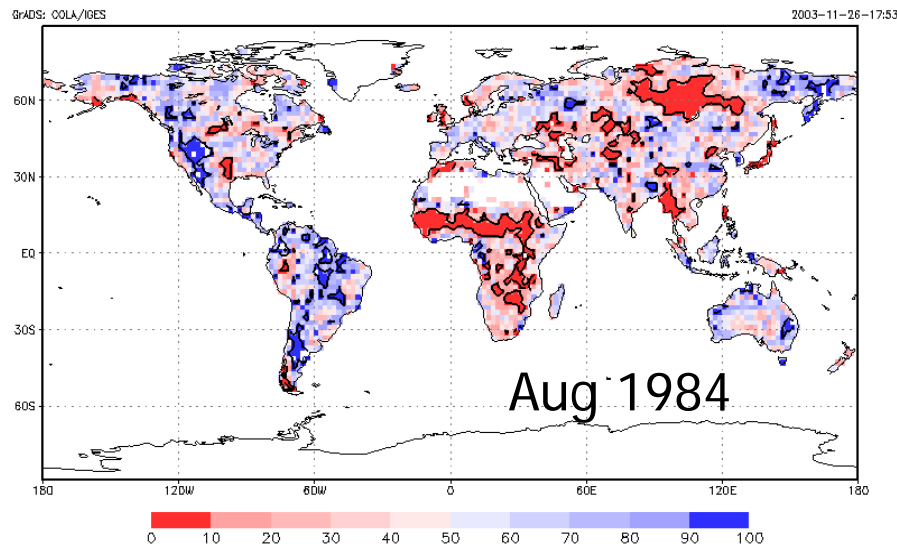
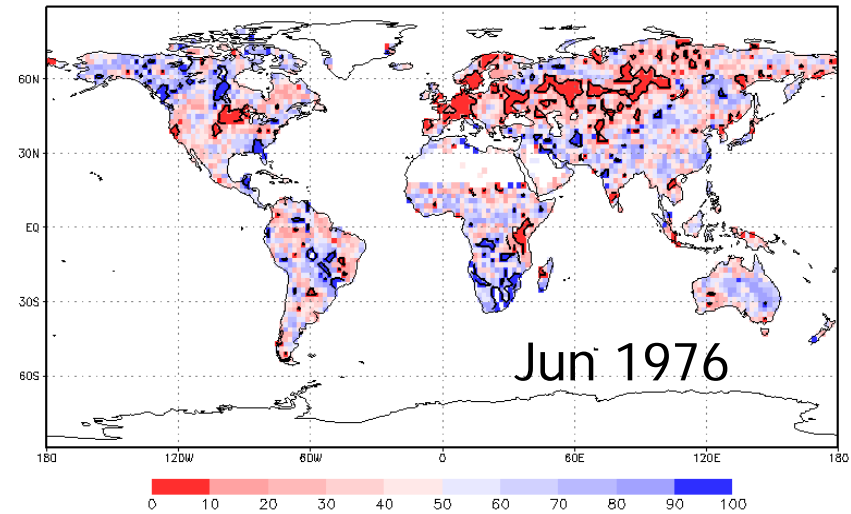
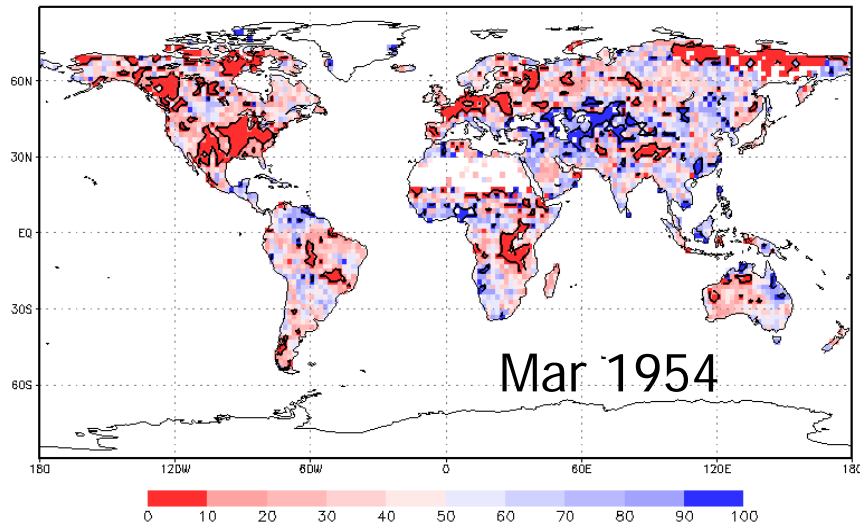

GrADS: COLA/IGES

2003-11-26-17:53

GrADS: COLA/IGES

2003-11-28-10:18

2. Historical Analysis: Drought over Africa

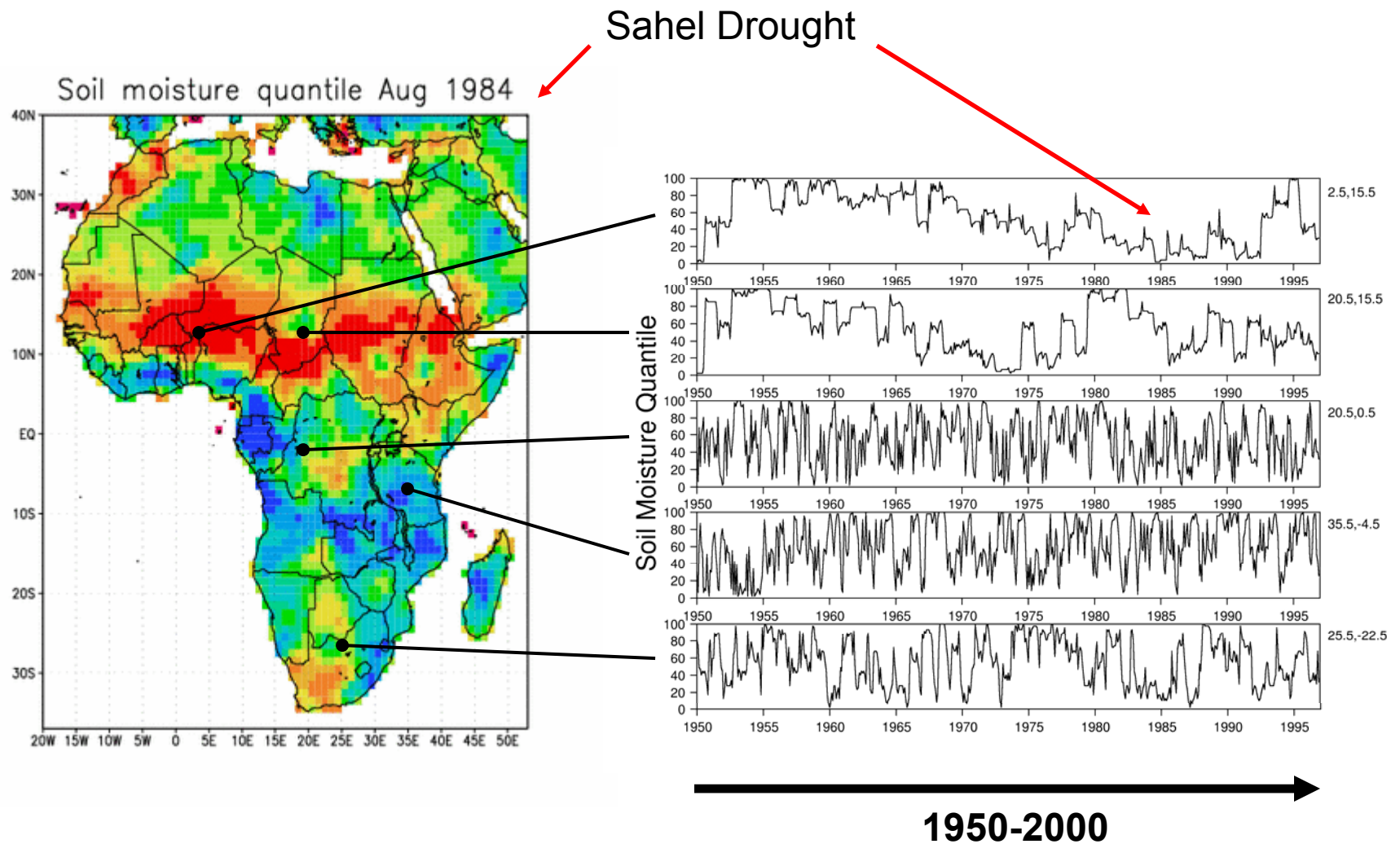

3. Understanding mechanisms: Recent drought in California

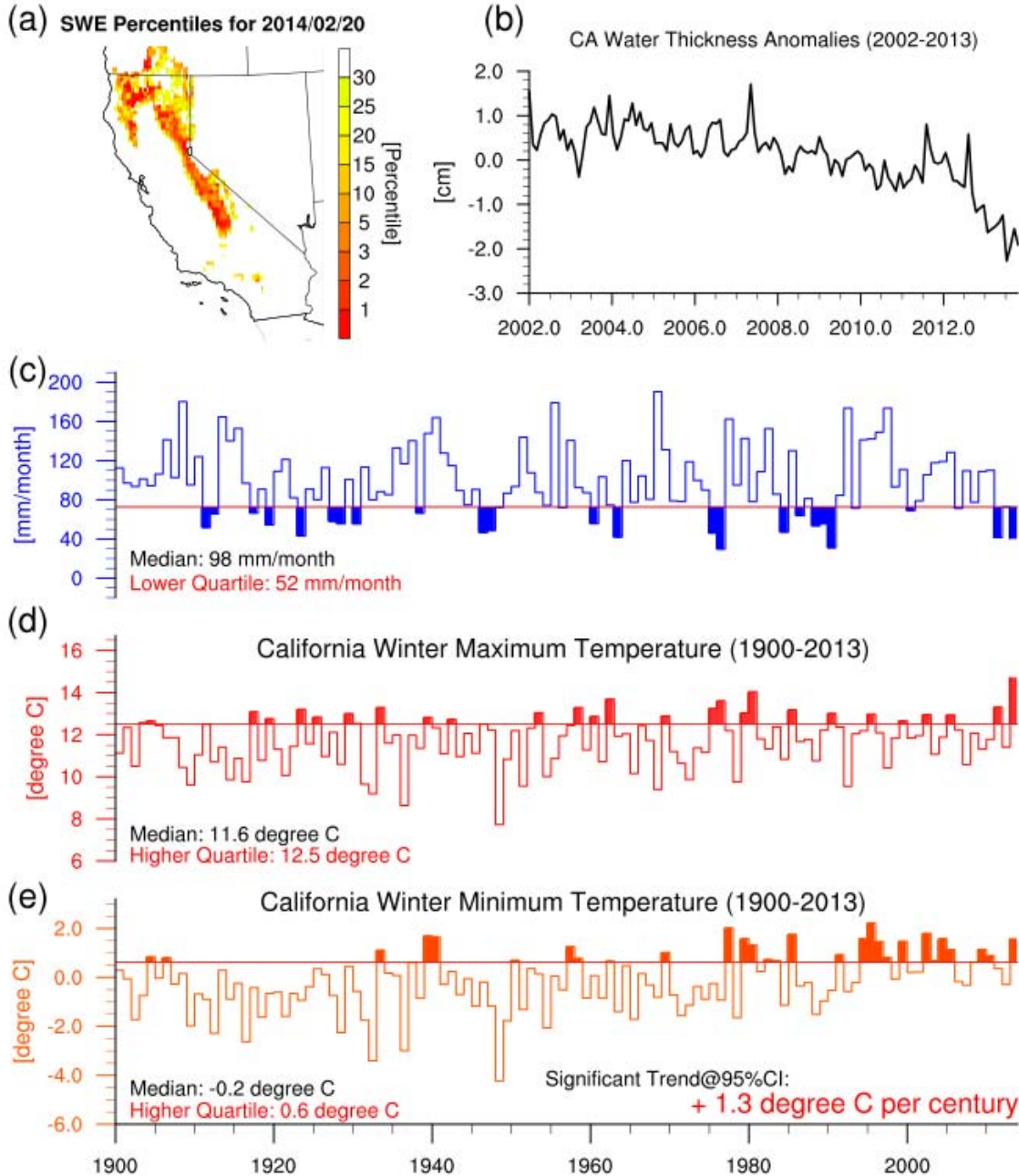

2013 Winter Drought

Atmosphere:

- Driest winter over 114 years

Temperature:

- Highest T_{max} over 114 years
- T_{min} : Significant increasing trend

Water storage:

- Negative water storage anomalies.
- Very low snow pack

2013: Perfect conditions for California wintertime drought



Risk analysis of drought in CA tells us that drought is more likely with different phases of ENSO, PDO, AMO, which also tend to differ between southern CA and northern CA.

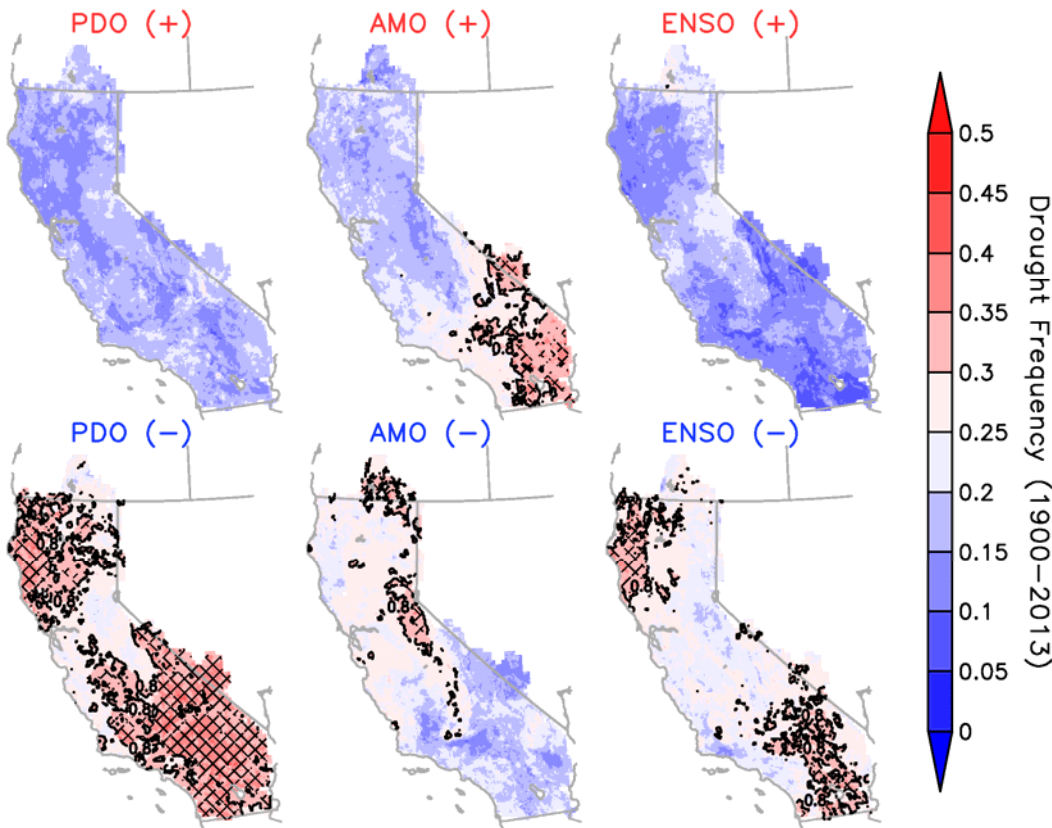

Recent ocean states have favored optimal conditions for CA drought

Future evolution of PDO and AMO imply continuation of favorable conditions for drought

Really depends on what ENSO does

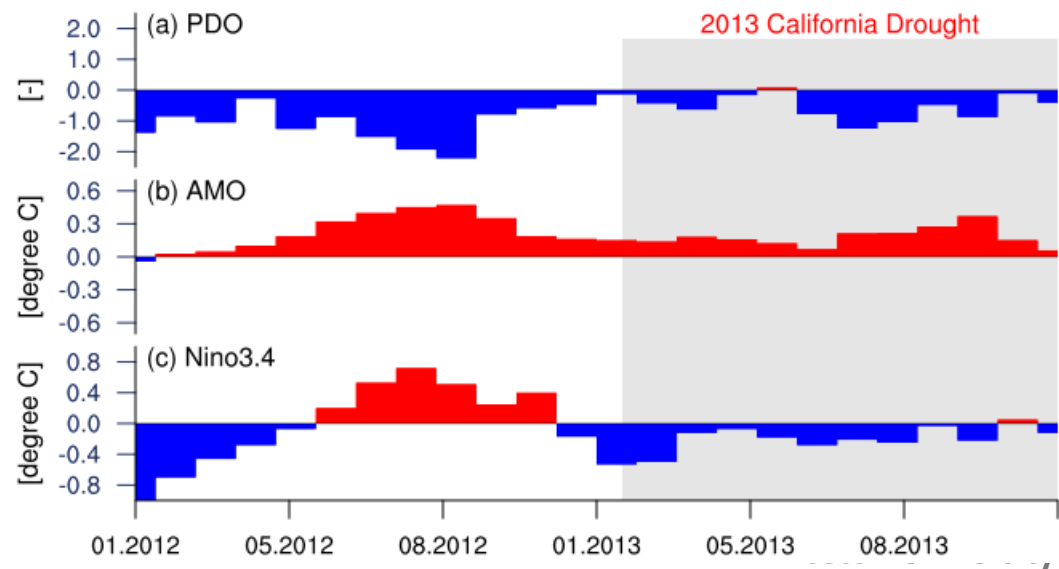

Development of a Hydrologic Monitoring and Prediction System

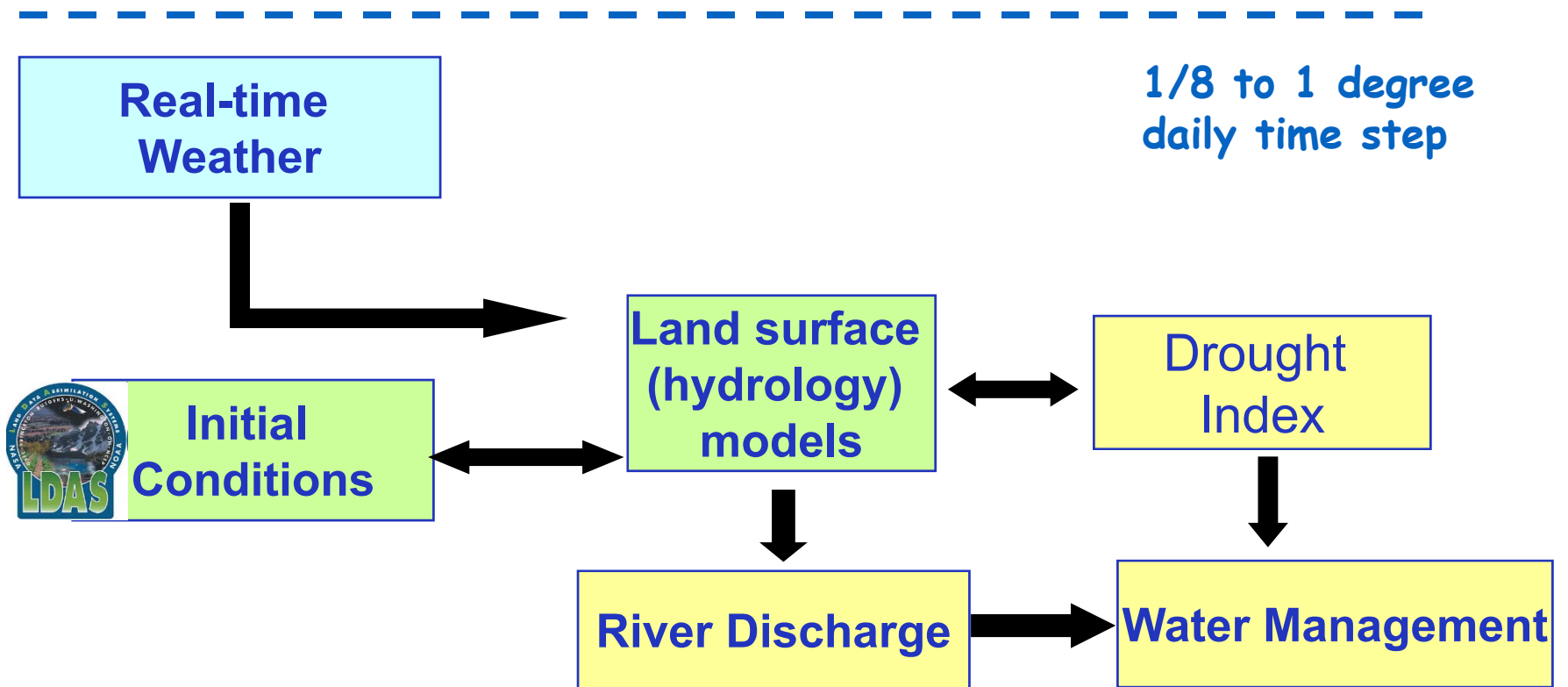

Development of a Hydrologic Monitoring and Prediction System

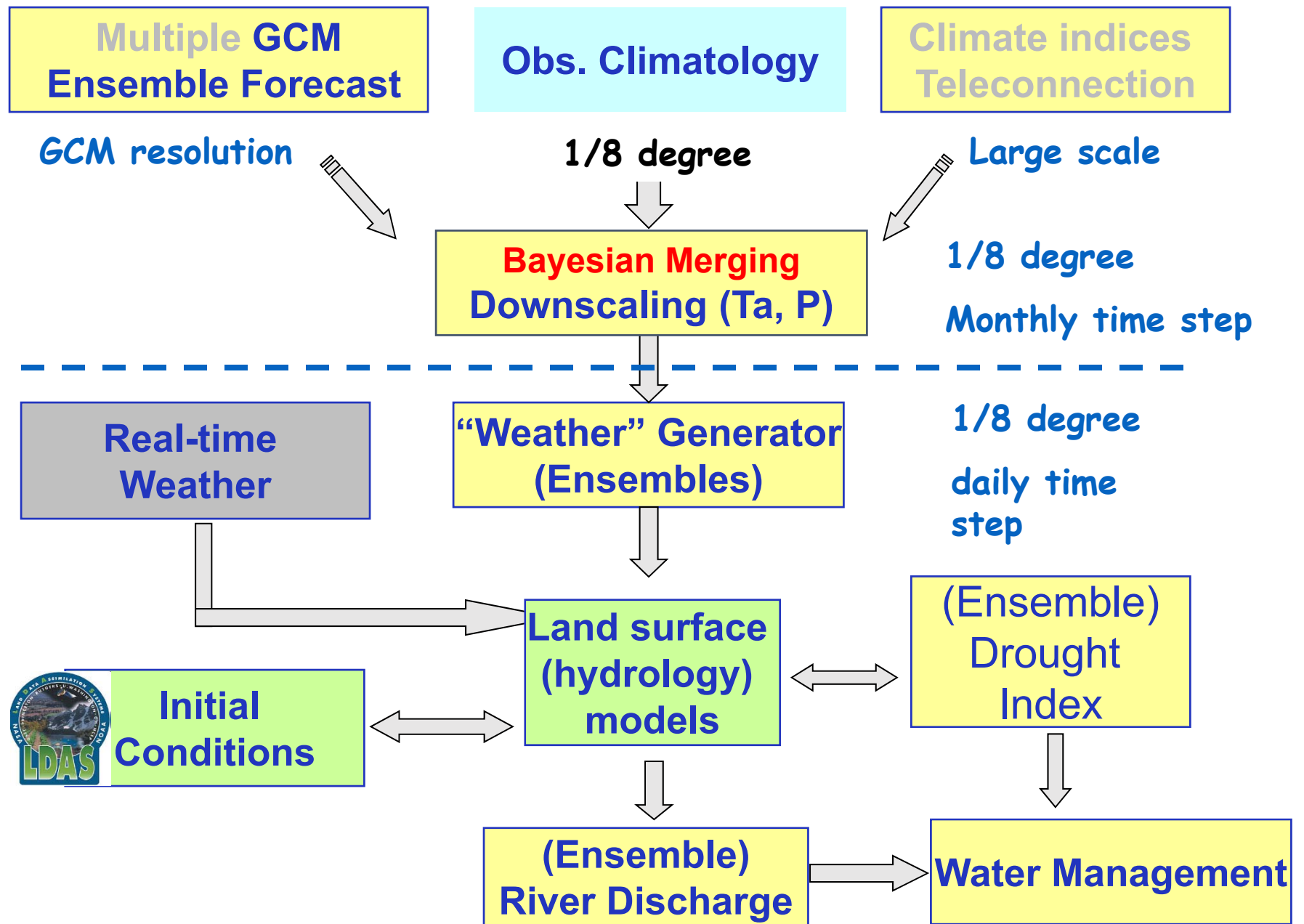

SPI6 for MAMJJA, 2011 & 2012

SPI6: Prior 3-month (MAM) observation with the current (JJA) 3-month forecast

2011

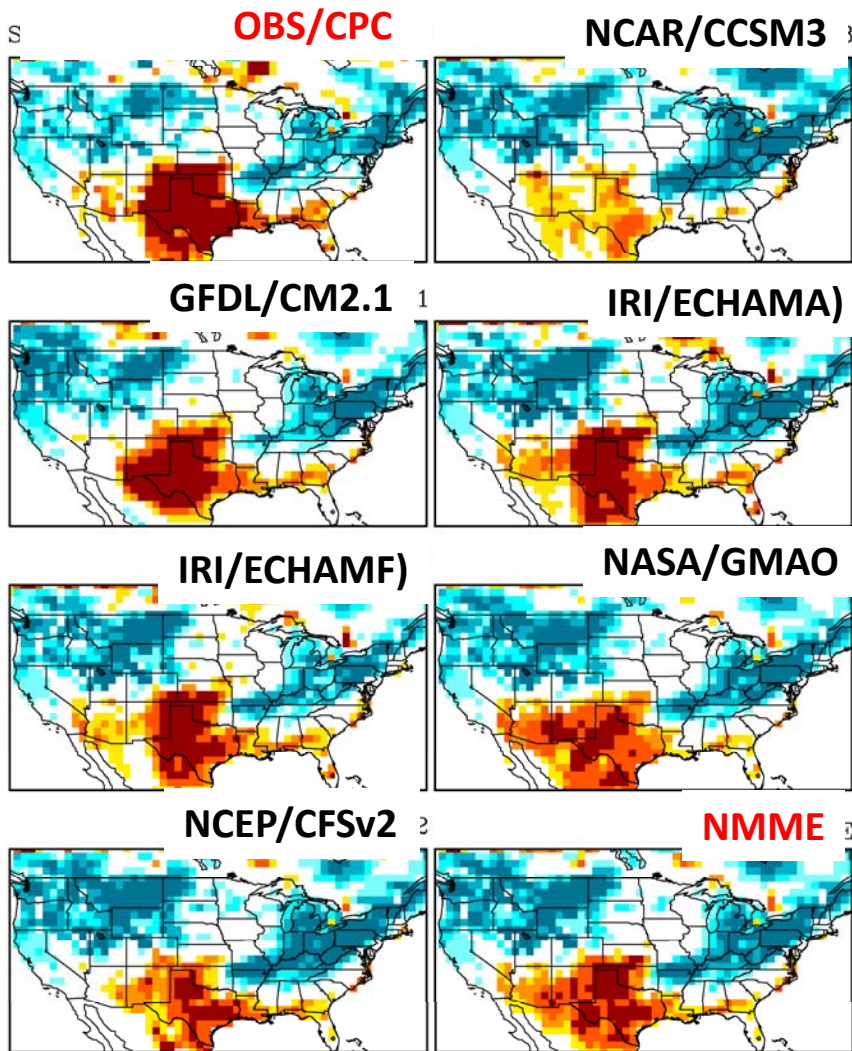

2012

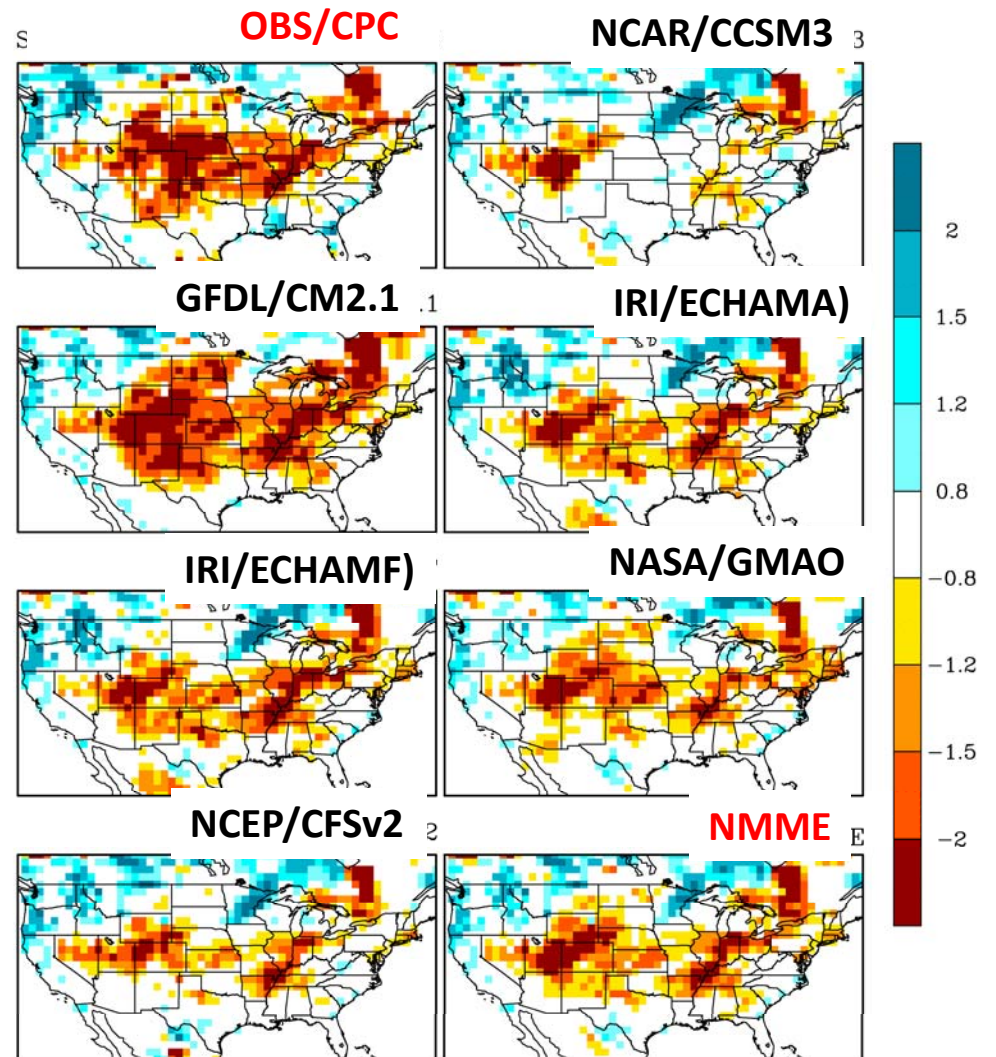

SPI6 for MAMJJA, 2011 & 2012

SPI6: Prior 3-month (MAM) observation with the current (JJA) 3-month forecast

2011 left 2012 right	
OBS (CPC)	NCAR (CCSM3)
GFDL (CM2.1)	IRI (ECHAMA)
IRI (ECHAMF)	NASA (GMAO)
NCEP (CFSv2)	NMME

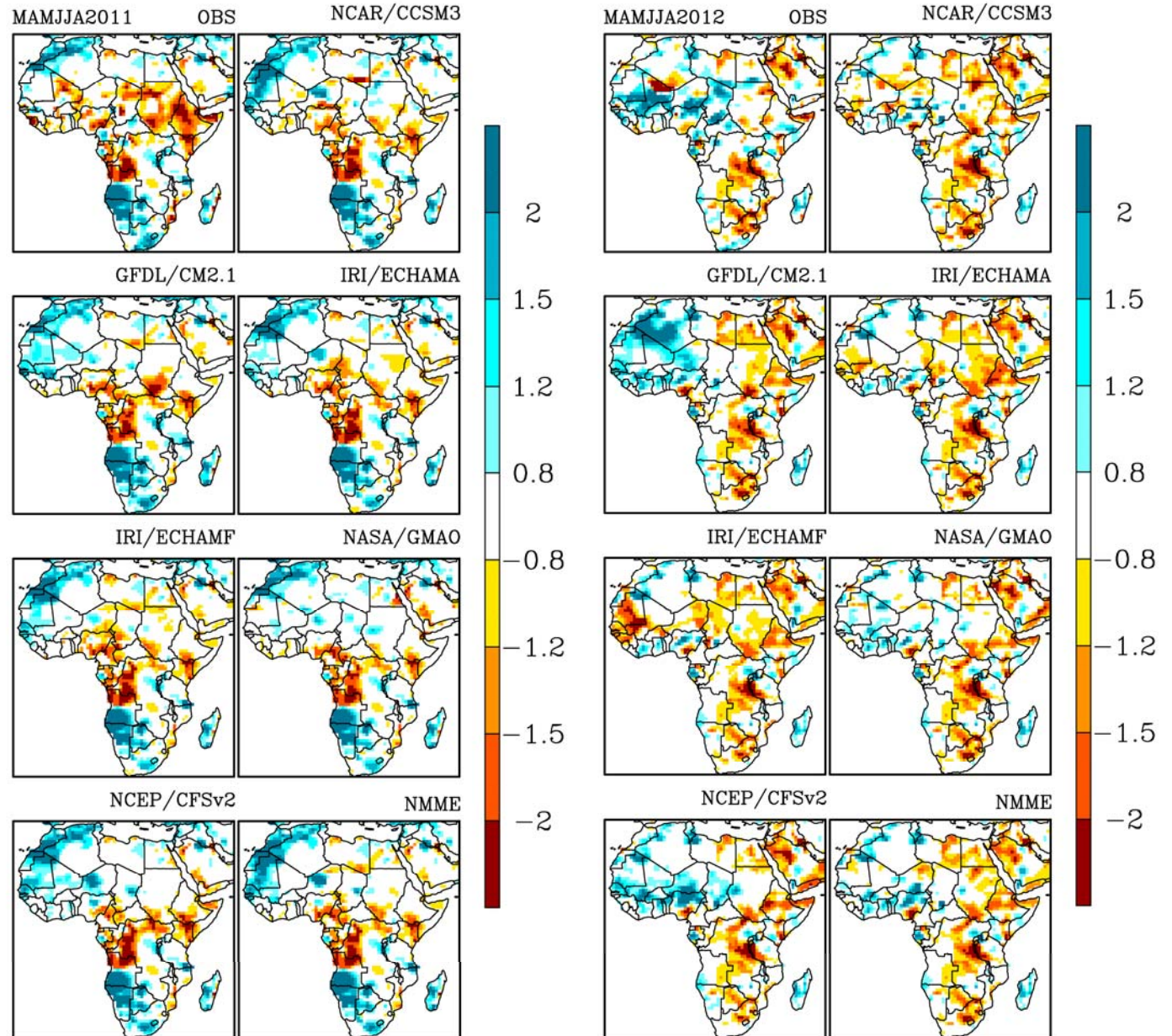

Streamflow Forecast (1988/05)

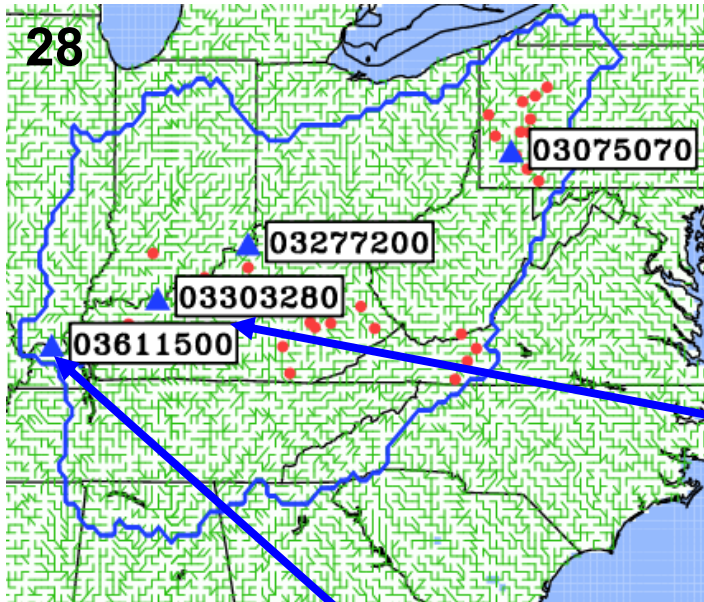

- **Obs Climo from USGS**
- **Obs. from USGS**
- **Offline simulation is obtained with VIC driven by observed meteorology**
- **CFS-based: Only CFS forecast is used in the merging and downscaling.**
- **Multimodel: Seasonal forecasts from 8 climate models are used in the merging and downscaling.**
- **Climatological Forecast: Random selection of historical forcing**

03303280: OHIO RIVER AT CANNELTON DAM AT CANNELTON, IN (97000.00 sq mile)

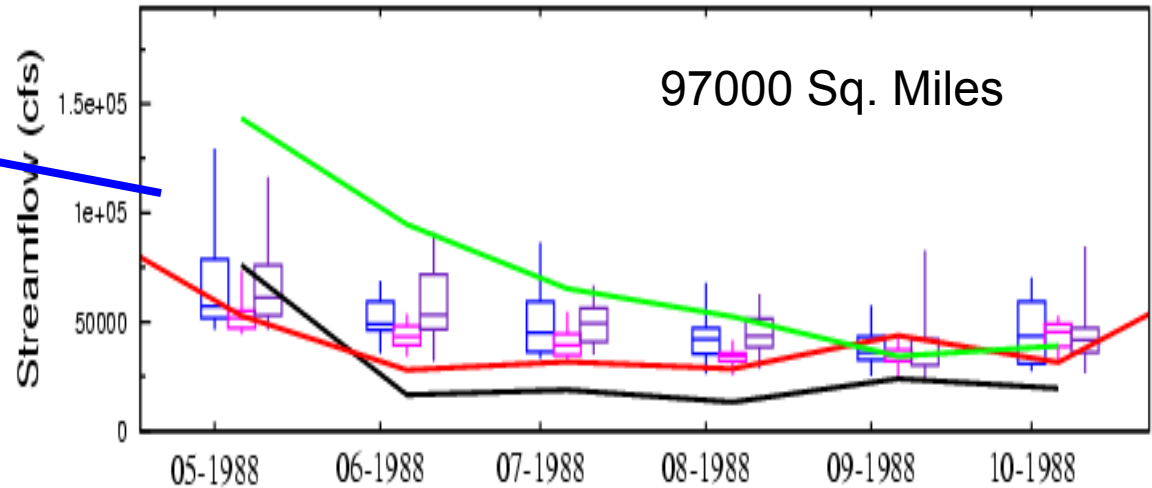

03611500: OHIO RIVER AT METROPOLIS, IL (203000. sq mile)

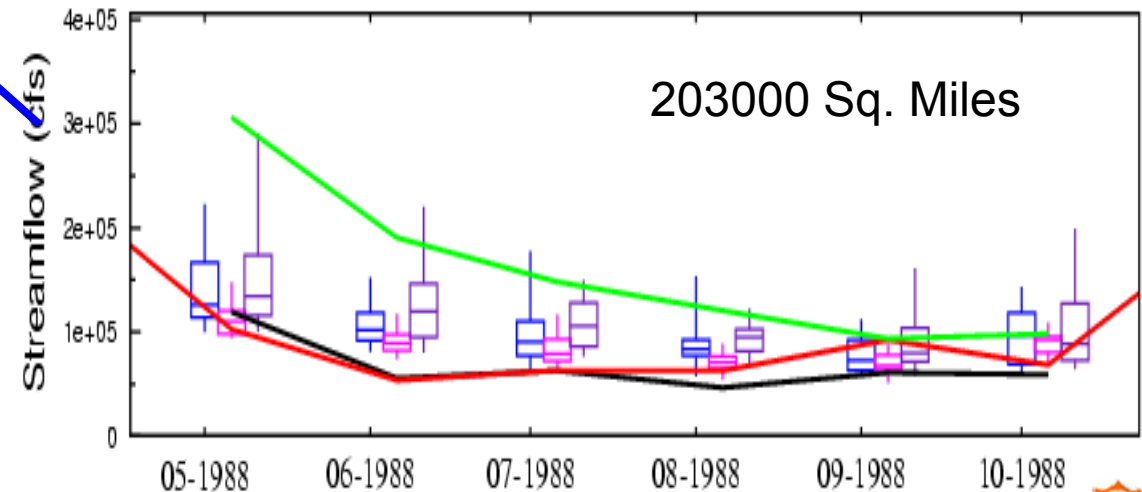

Princeton's African drought and flood monitoring and forecasting system

<http://stream.Princeton.edu>

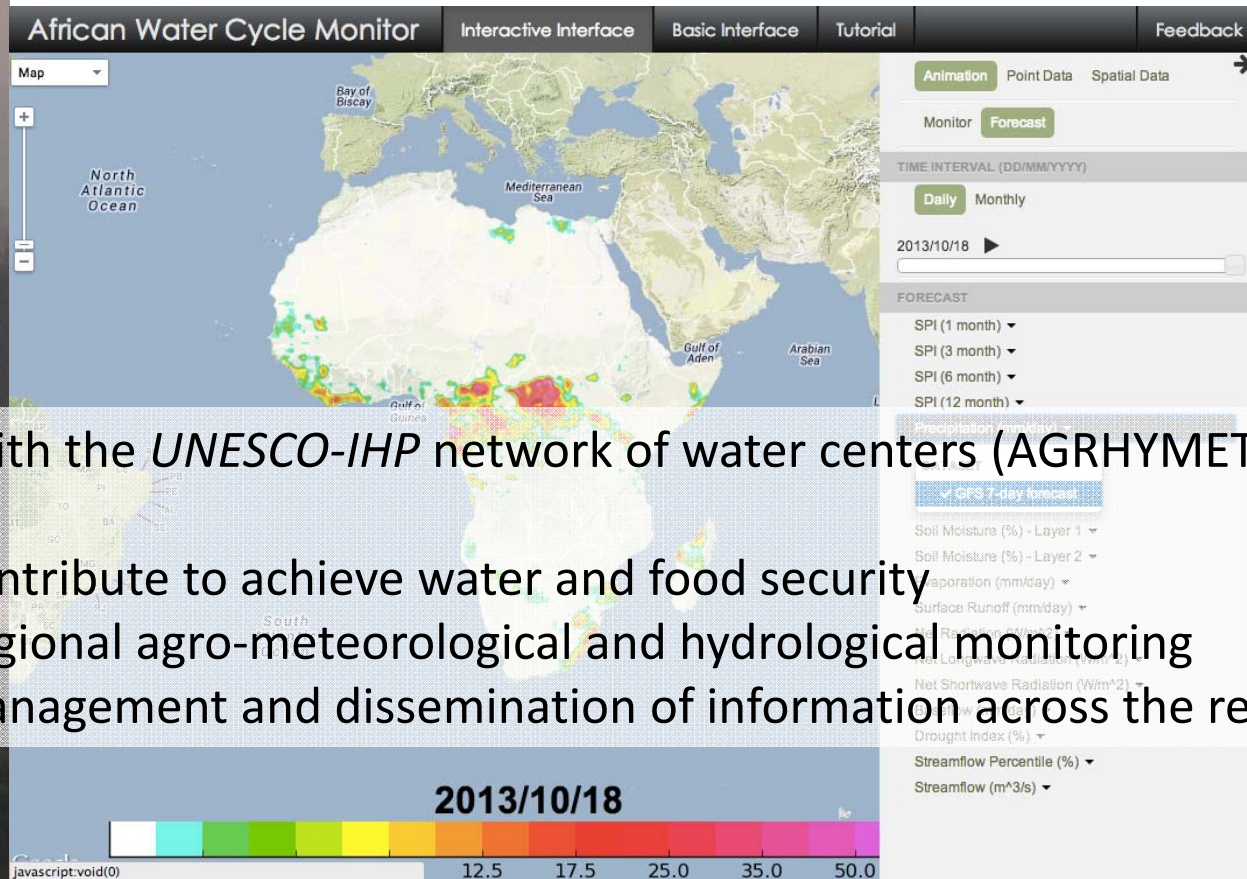

Partner with the *UNESCO-IHP* network of water centers (AGRHYMET, ICPAC, SADC, ...)

- Contribute to achieve water and food security
- Regional agro-meteorological and hydrological monitoring
- Management and dissemination of information across the region.

Princeton African Drought Monitor: Interactive User Interface

- Animation of hydrologic variables
- Catchment data
 - Over 800+ basins from the GRDC network and FAO Reservoir database.
- User control is enhanced.
- Overlay basin maps
- Zoom in to regions of interest
- Access data record from 1950 – present.

User interface

Initial Time: 8 1 2012 (- +)
Final Time: 8 1 2012 (- +)
Frames per second: 1
Update time interval Clear all overlays
Image opacity: (- +)

Meteorology (?)

- Precipitation (mm/day)
- Maximum Temperature (C)
- Minimum Temperature (C)
- Wind (m/s)

Hydrologic Variables (?)

- Evaporation (mm/day)
- Soil Moisture(%) - Layer 1
- Soil Moisture(%) - Layer 2
- Surface Runoff (mm/day)

Drought Products (?)

- Drought Index

Catchment Data (?)

- Stream Gauges (8/1/2012)

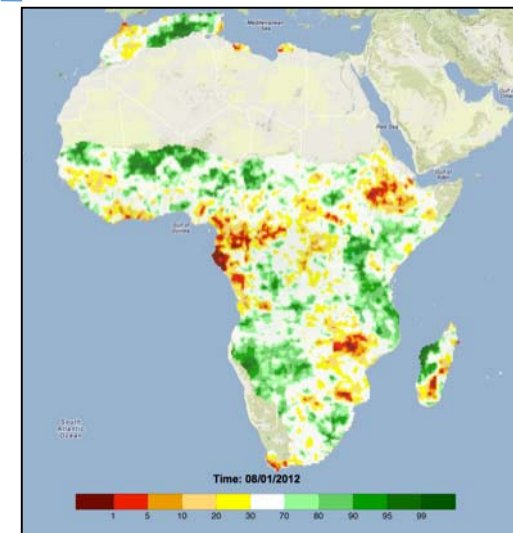
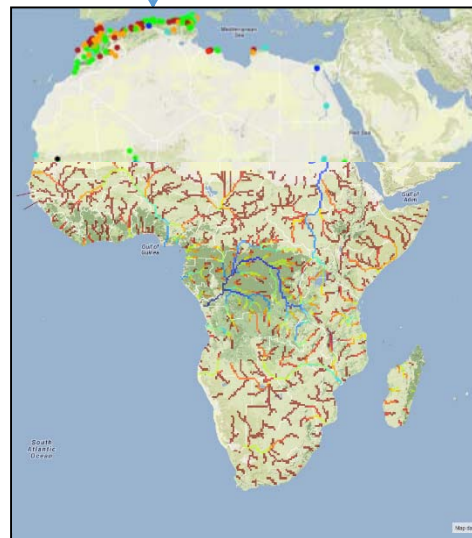
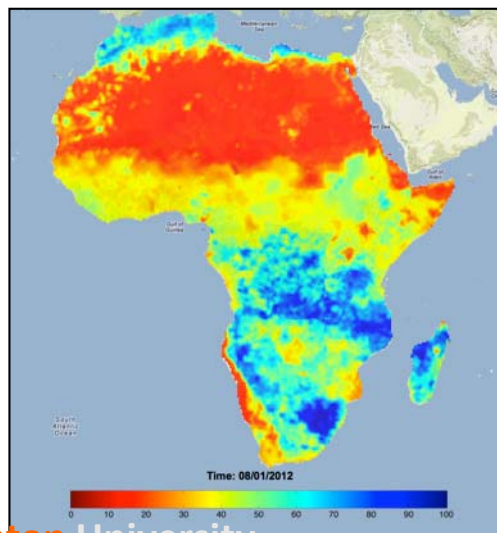
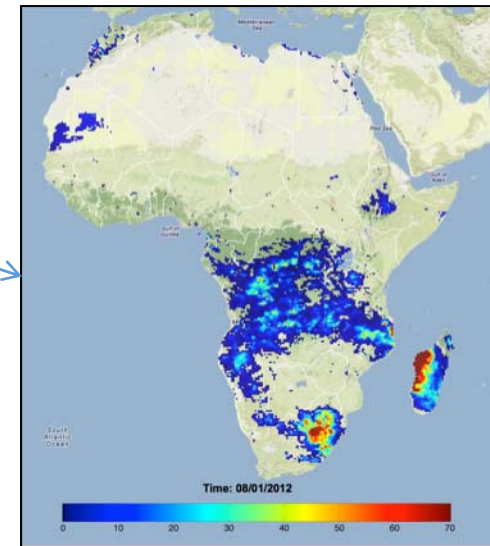

7-day forecasting based on NCEP's GFS

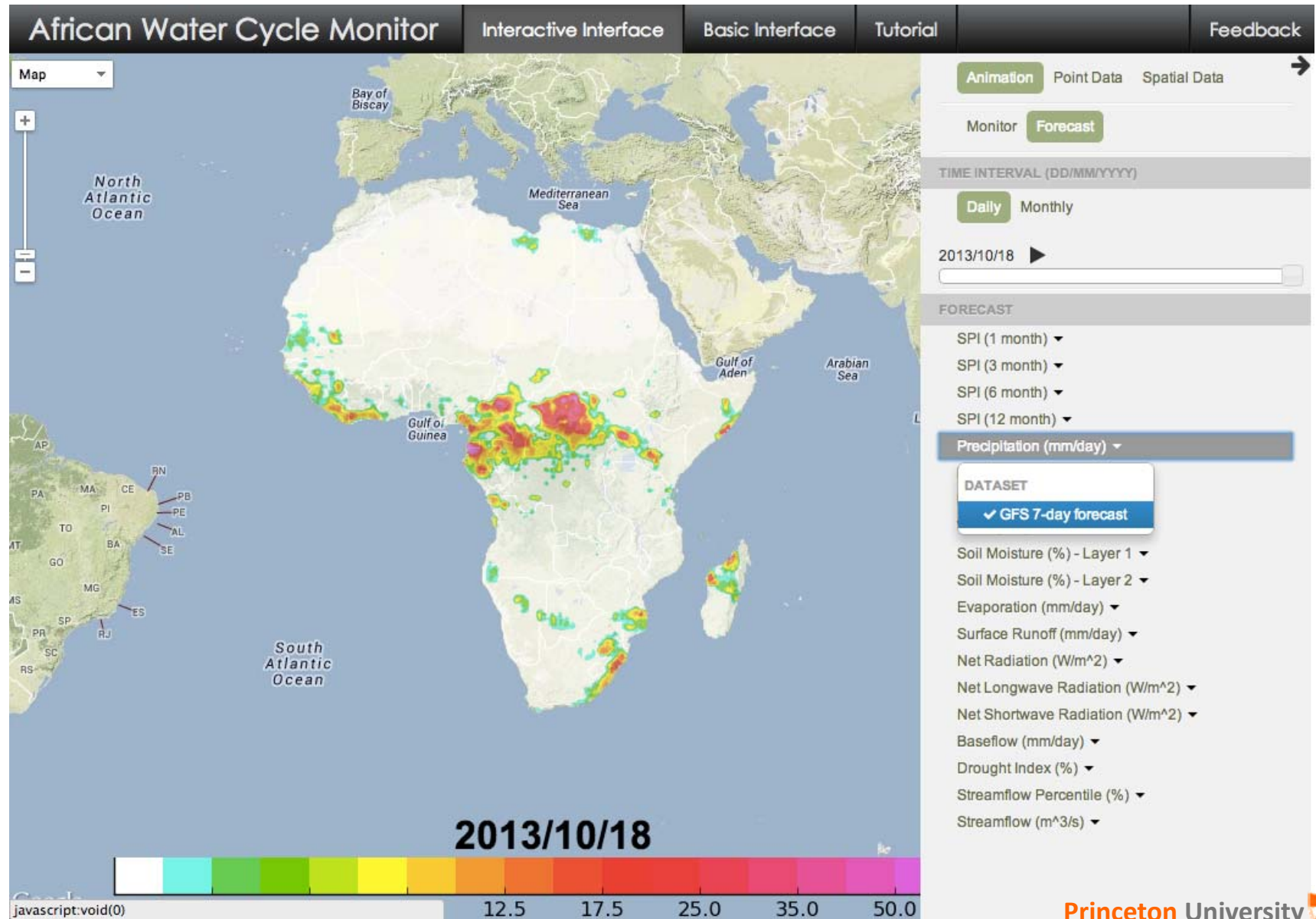

Streamflow Monitoring and Short-Term Forecasts

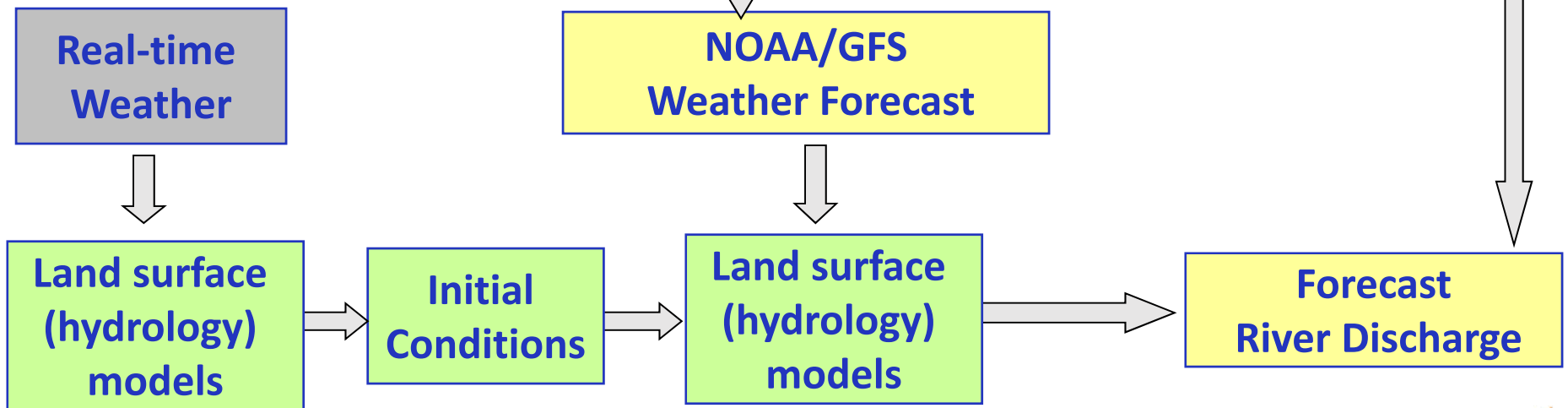
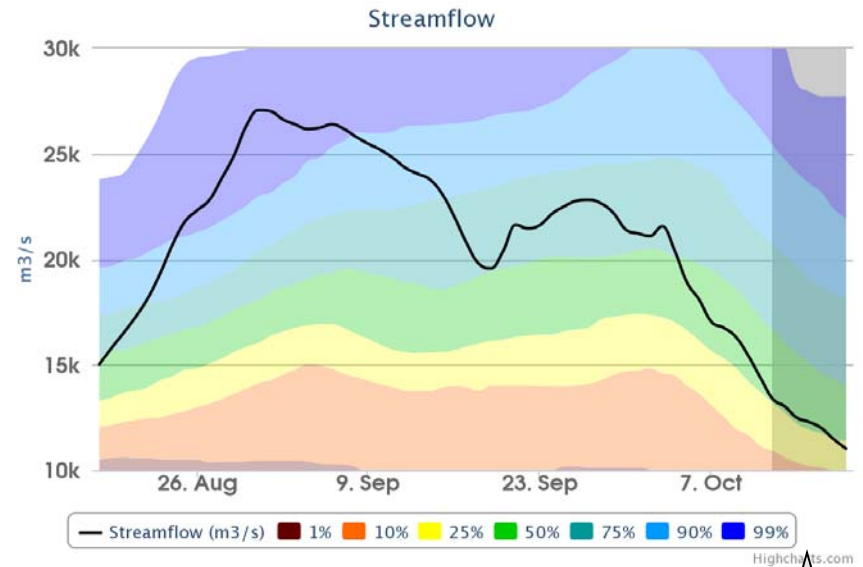
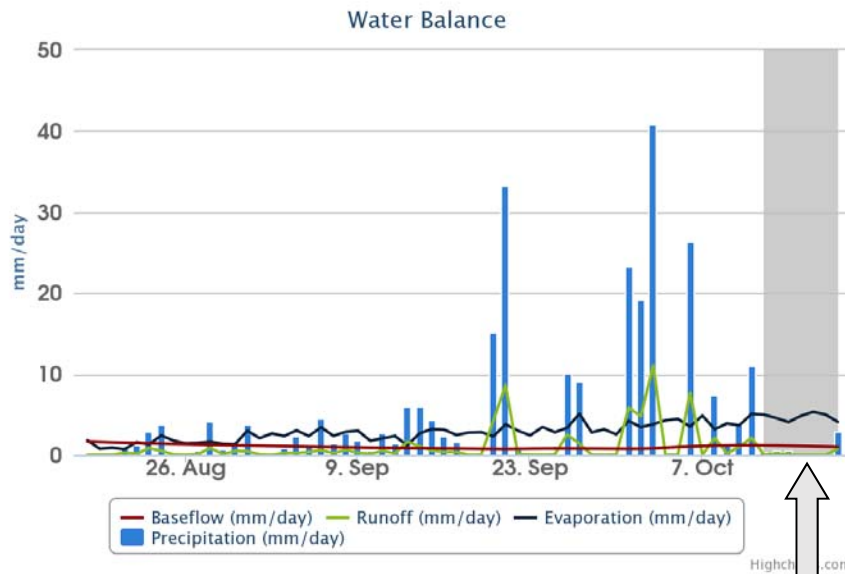

Seasonal SPI-6 (6-month) forecast (e.g. for 2/14 from 9/13)

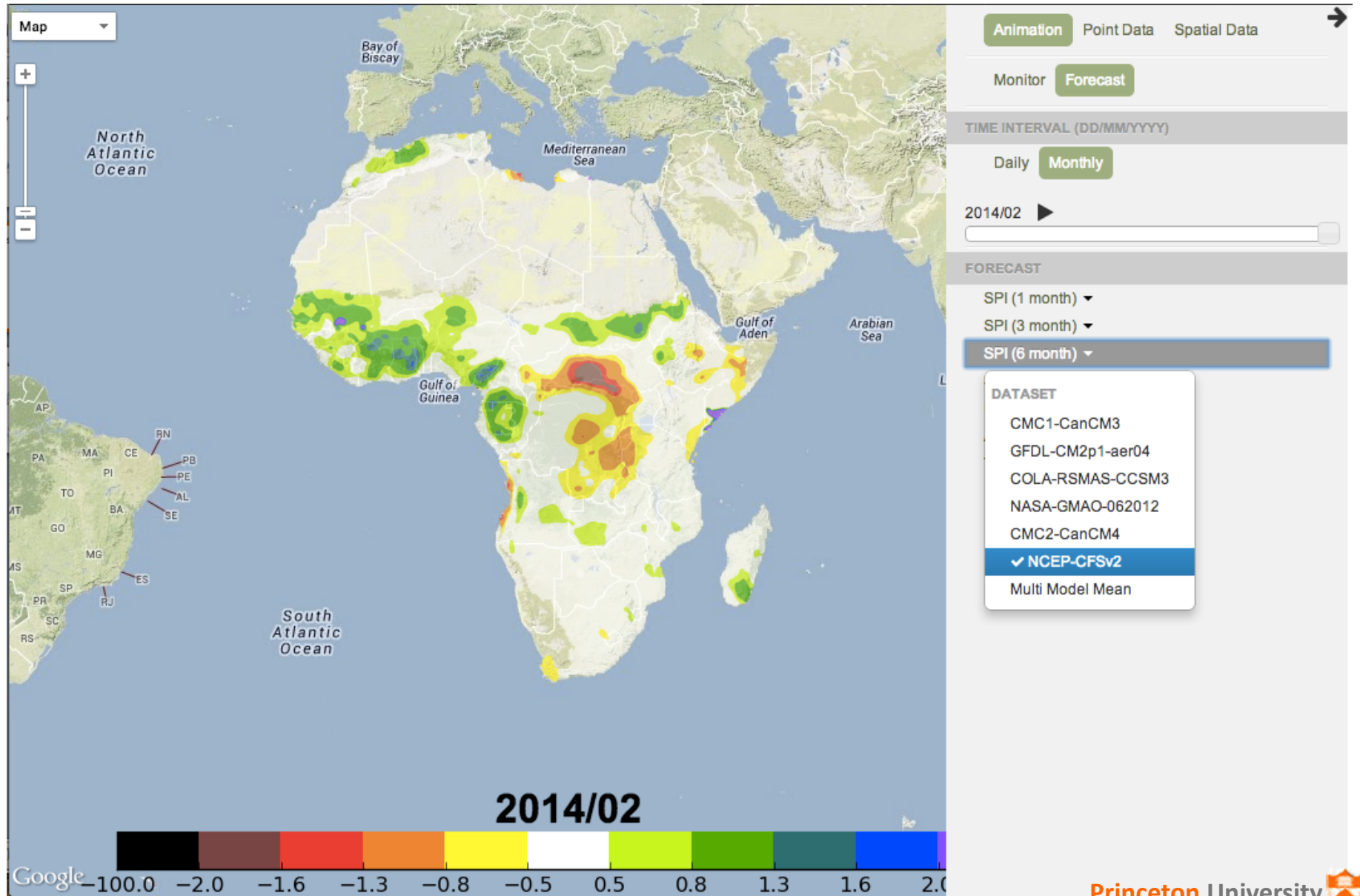

Regional Example: Horn of Africa Drought 2010-2011

← Monitoring the propagation of the drought

Seasonal drought forecasts
(based on CFS model only)

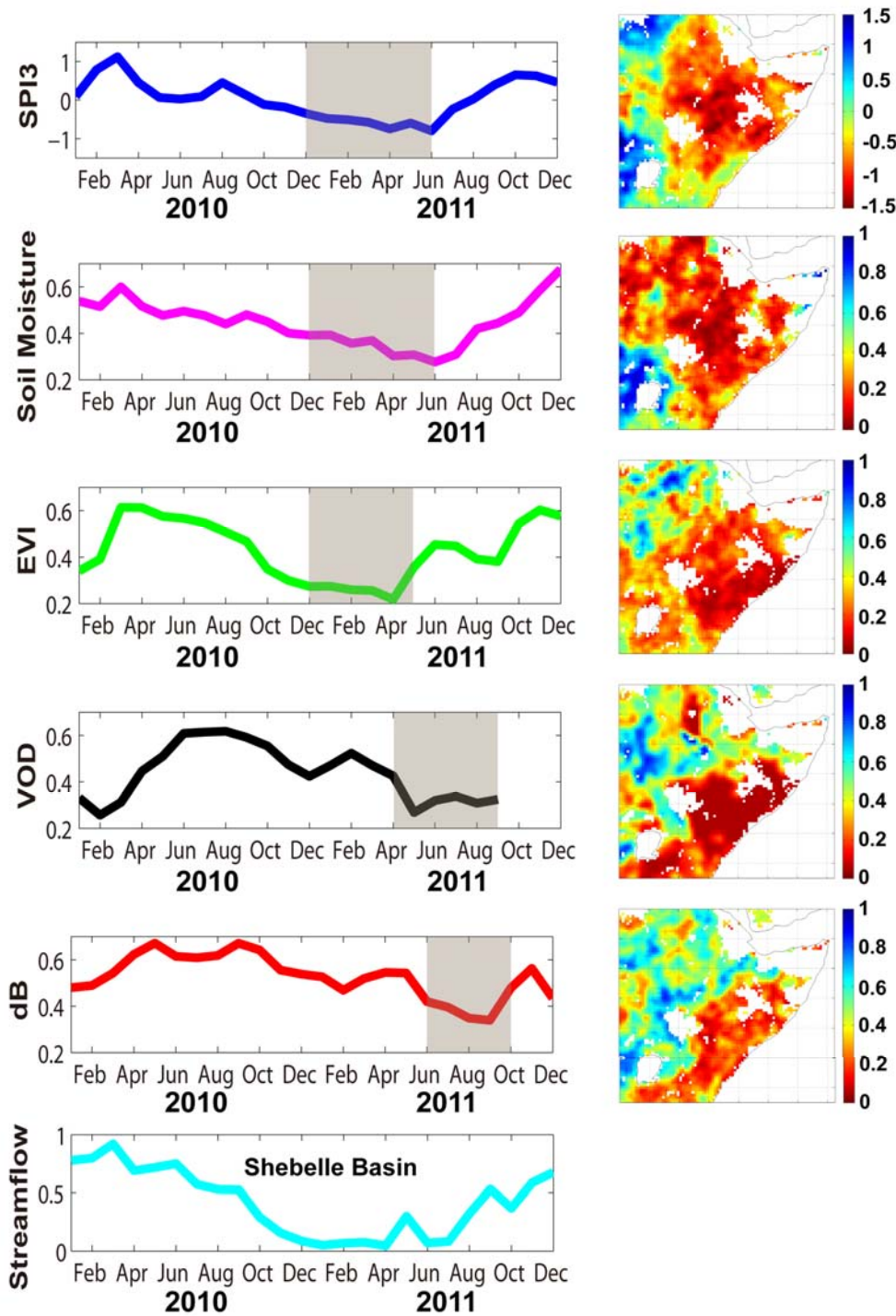
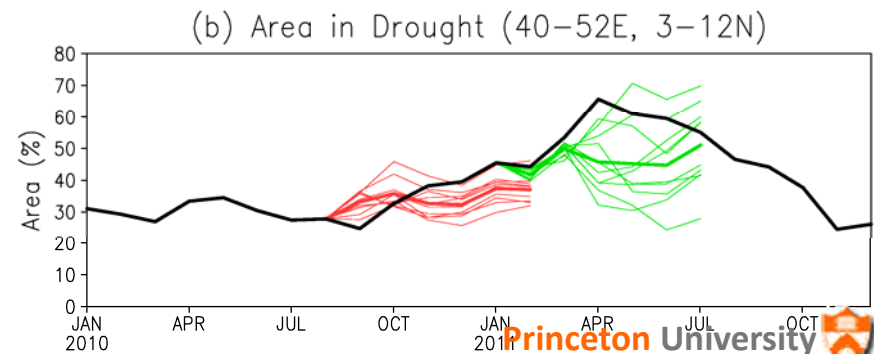
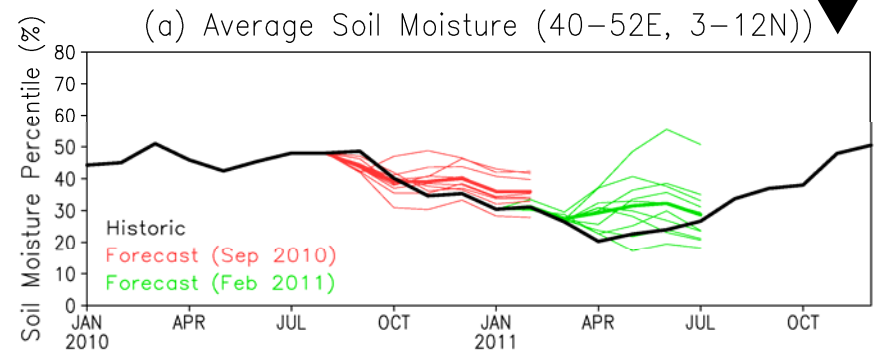

Transfer ADFM to AGRHYMET (1/2012; 10/2013) and ICPAC (June,2012)



Goals:

- Adapt the monitoring system to the region.
- Improve data dissemination, knowledge exchange
- Provide training and allow for feedback at workshops (participatory exercises)
- Followed by validation plans, operational evaluations, exchange visits, ...

Transfer of drought monitoring systems and information portals to local centers for assimilation of local knowledge/data and with training is critical.

Expansion to a global monitoring capability

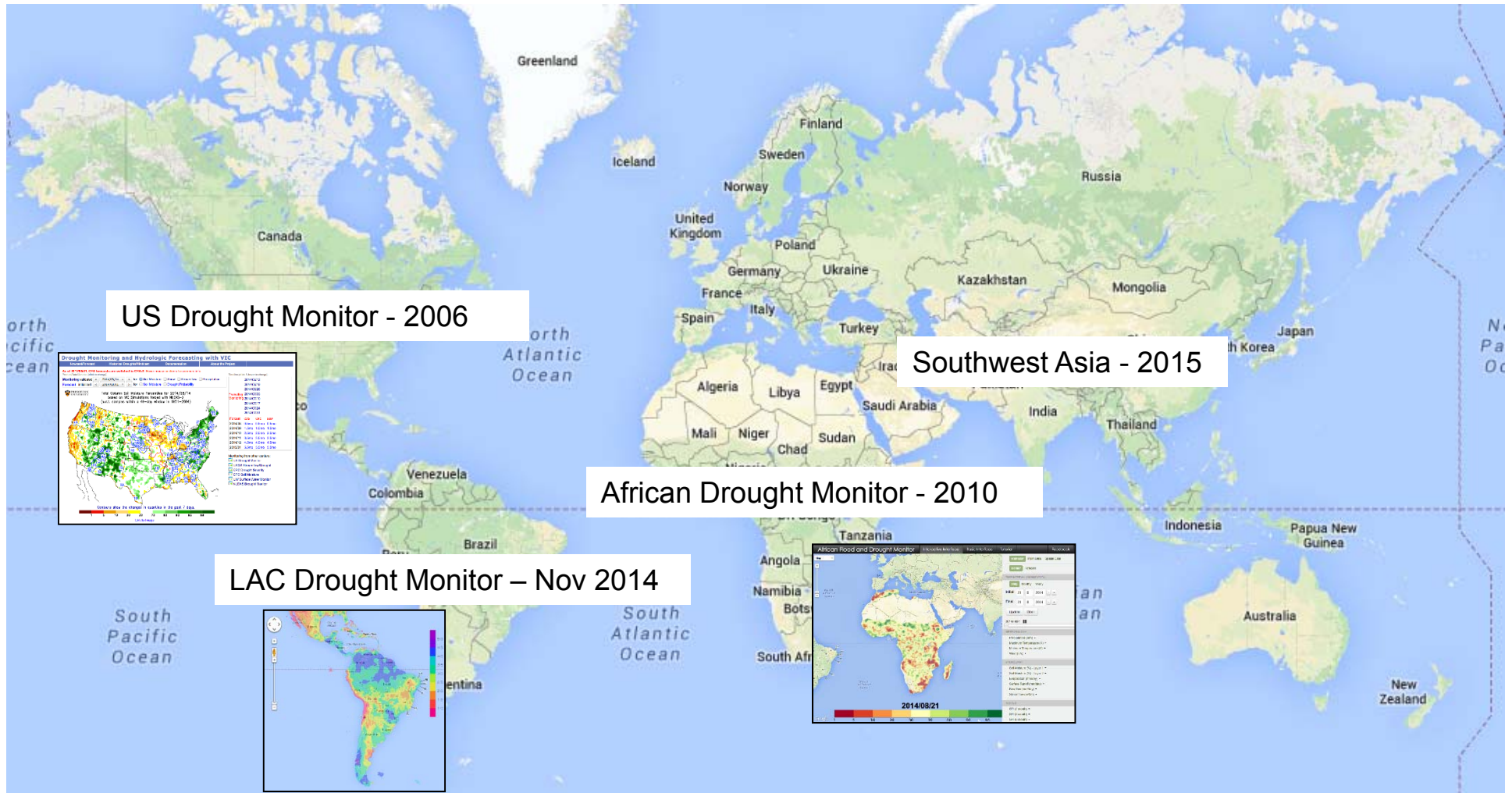

See stream.princeton.edu

The information transfer challenge – empowering local people

How can local communities obtain weather and drought information to help them make decisions and developing coping strategies?

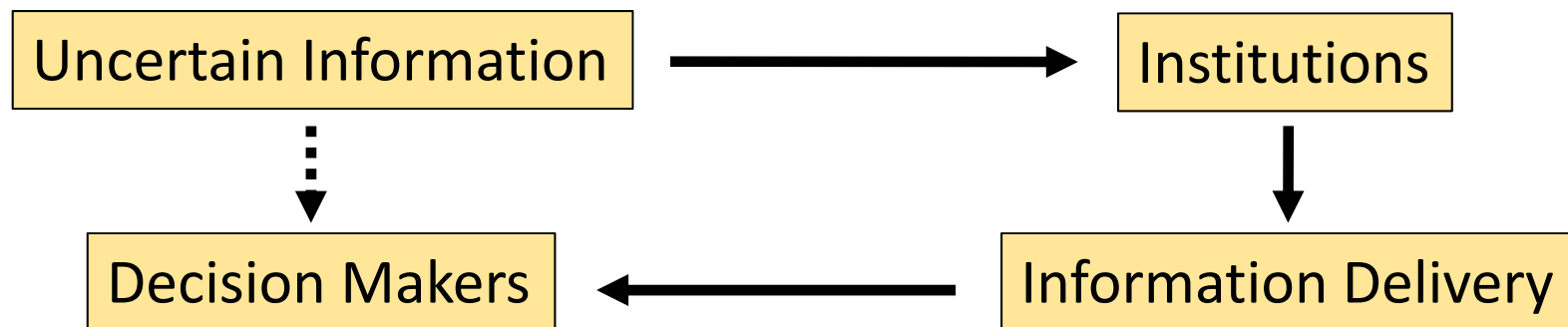

The information transfer challenge – empowering local people

How can local communities obtain weather and drought information to help them make decisions and developing coping strategies?

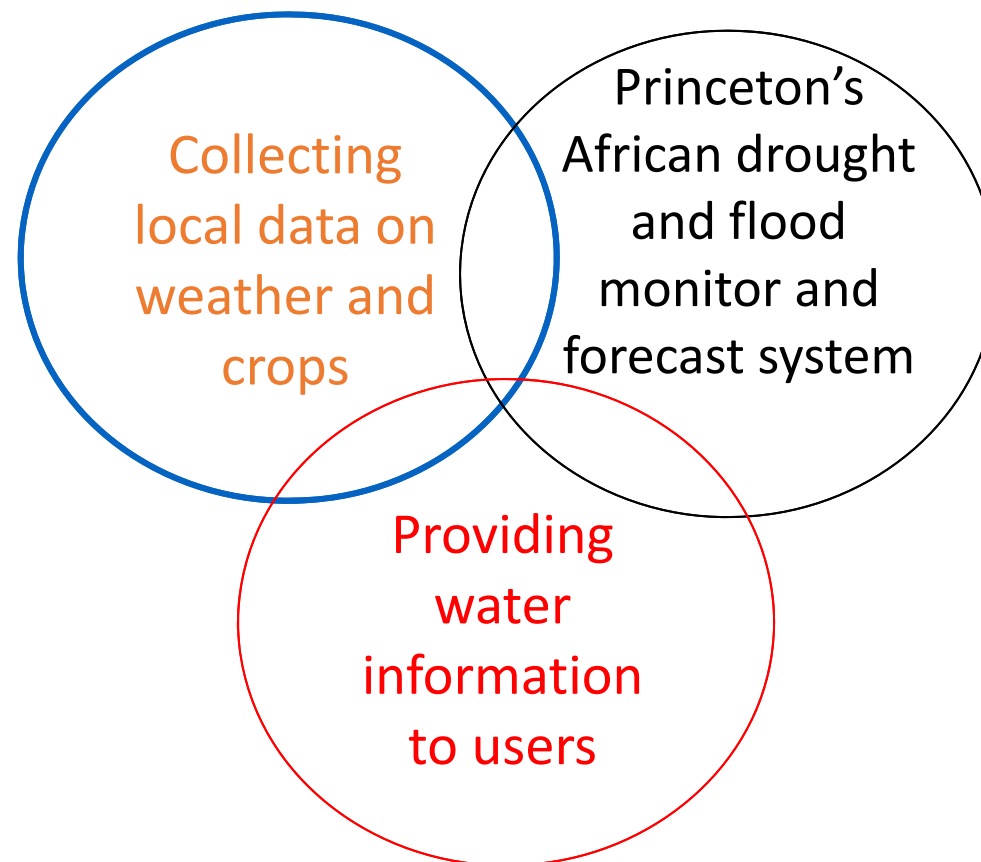

Some **Big** Challenges

1. **Identifying new sources of observational data** to enhance real-time monitoring and improve initialization of forecasts; improving forecast skill at time and space scales relevant for decision making
2. How **knowledge/technology can be transferred to universities and practitioners for sustainable solutions** to achieving water and food security, and improve livelihoods for mitigation and improved resilience?
3. **Understanding the utility of climate/drought information** to
 - (i) inform policy making at national scales and
 - (ii) improve rural agricultural decision making

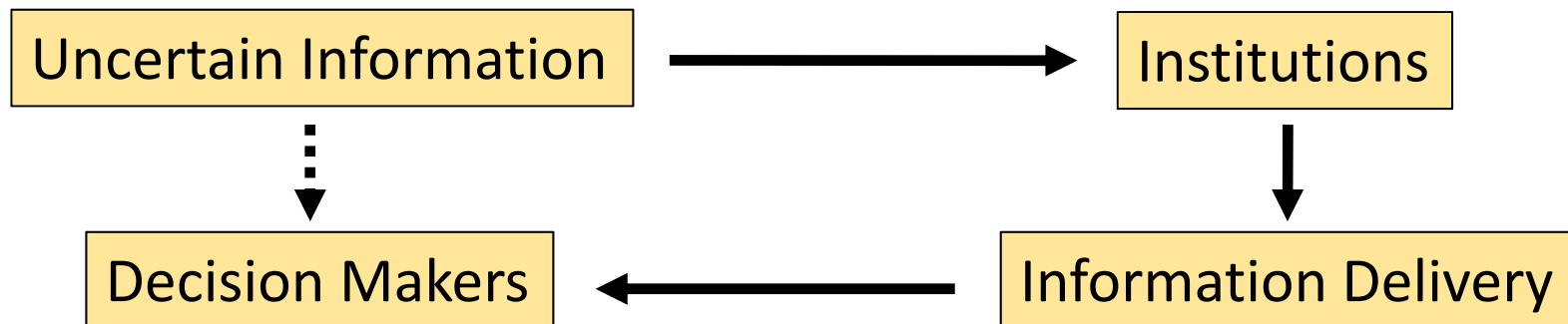

Overcoming the Lack of Observations: Potential of Low-Cost Environmental Sensors Communicating over the Cell Network

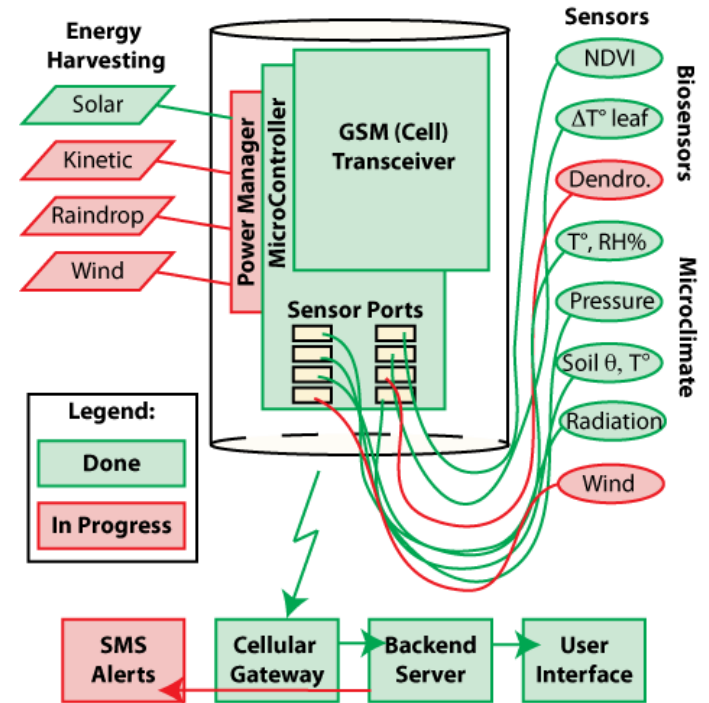
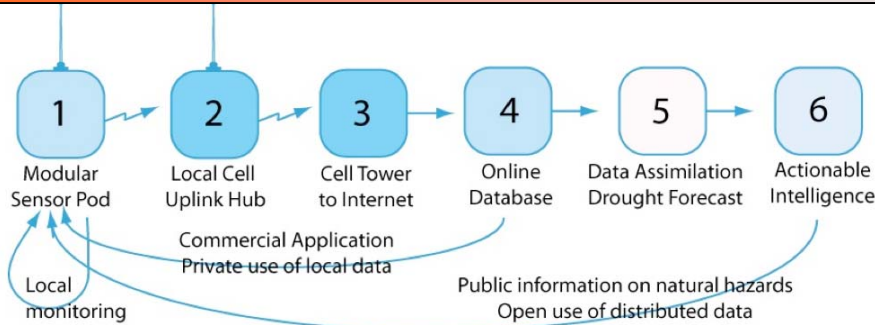

**There's a large and rapidly growing
cellphone network in sub-Saharan Africa**



The infrastructure is maintained by private sector
and is ubiquitous in populated areas



And communicating in **real-time** to local users

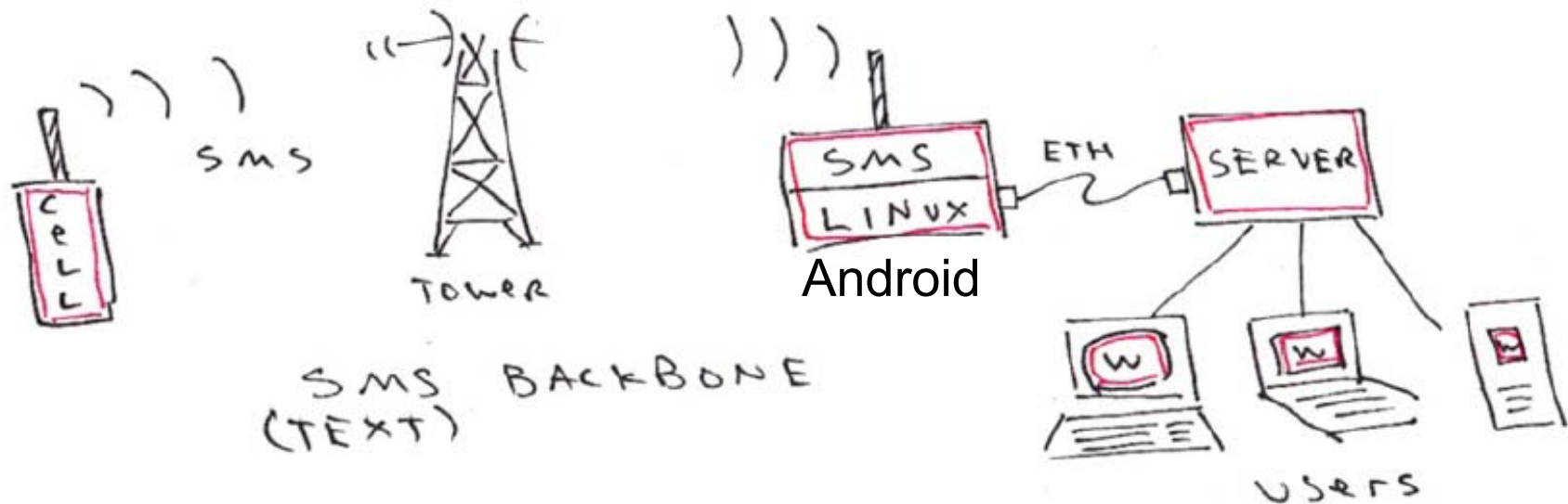

Pods send SMS messages to a gateway that posts messages onto the internet

There is Potential to Improve Information Utility and Transfer to Decision Makers

Alternative pathways of information delivery to users.

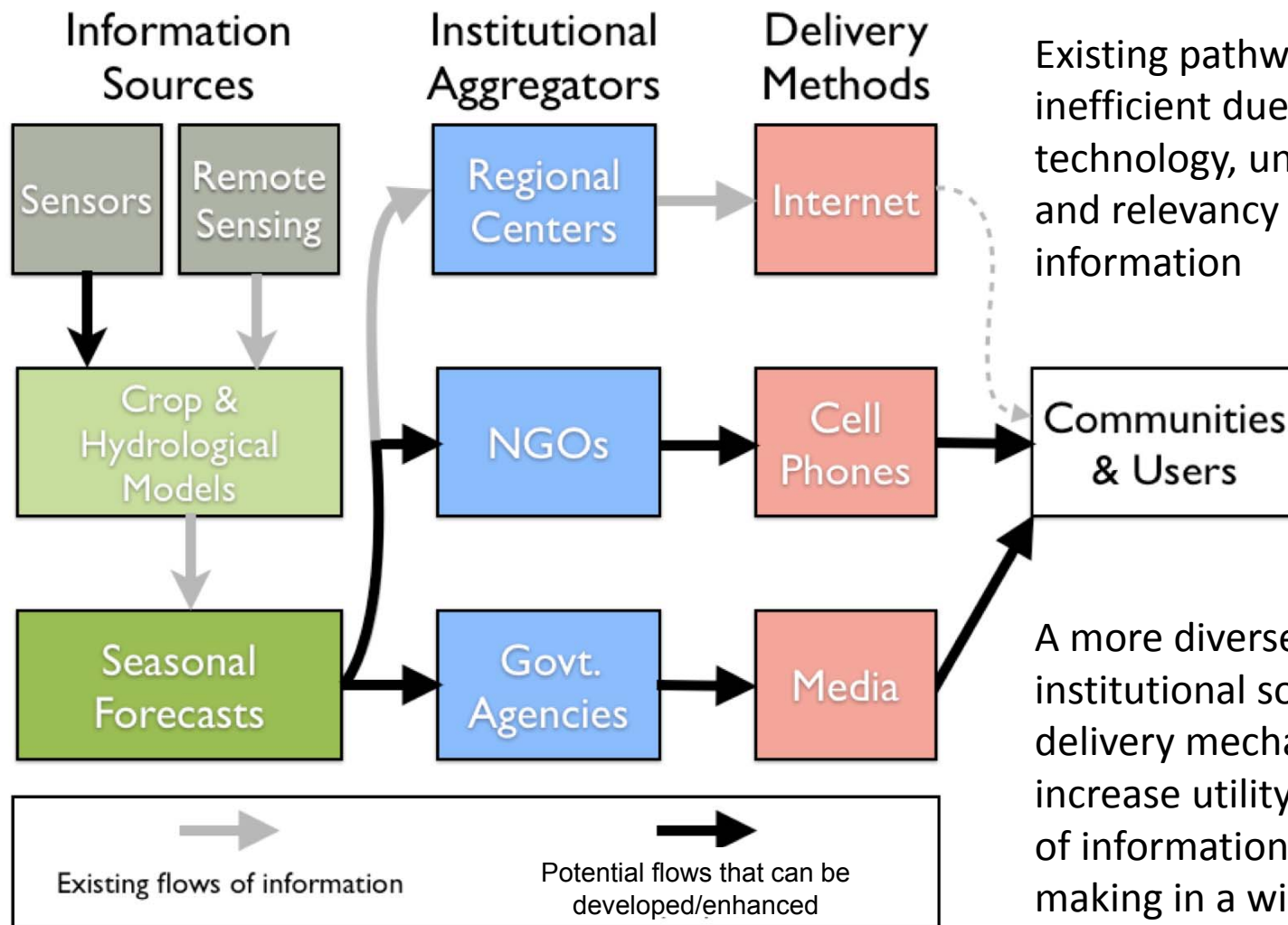

Existing pathways may be inefficient due to lack of technology, understanding and relevancy of the information

A more diverse suite of institutional sources and delivery mechanisms may increase utility/specificity of information for decision making in a wider range of contexts.

Summary and Future Activities

1. We've developed a drought research plan that has a continuous, consistent framework of historic analysis, monitoring, seasonal forecasting, and climate change projections;
2. This framework is being used to develop a global capability based on historical observations, real-time in-situ and remote sensing data, land surface modeling, seasonal forecasting, and climate projections;
3. The framework allows us to analyze drought risk at all temporal scales (historical, current and future), assess skill in seasonal forecasts and evaluate impacts such as water and food security.

